



Rechargeable Li-ion Battery

FB-L-16

Operation Manual

Information Version: 1.0
5PMPA08-20067

Legal Information

Copyright©2025 Pylon Technologies Co., Ltd. All rights reserved.

Any reproduction or distribution of this manual or any part of this manual, or any uploading of this manual to a third party website, in any form by any means, without the prior written consent of Pylon Technologies Co., Ltd., is prohibited.

Disclaimer

The manual contains instructions for the use of the product. All the pictures and charts in this manual are for description and explanation only. Pylon Technologies Co., Ltd. reserves the right to change the information in the manual which is subject to change without further notice.

Please read this manual carefully before using the product and keep this manual for further reference. Failure to use the product in accordance with the manual may result in serious injuries, property damages and may void the warranty, for which Pylon Technologies Co., Ltd. shall not be liable.

Pylon Technologies Co., Ltd. makes no representations or warranties express or implied, with respect to all the information in this manual.

In the event of any conflicts between this manual and the applicable law, the latter prevails.





The final interpretation of this manual belongs to Pylon Technologies Co., Ltd.

About this Manual

Purpose

This manual describes the Pylontech Fidus battery FB-L-16 and FB-L-16-Pro in terms of their overview, installation, commissioning, etc. Please read this manual before installing the battery and follow the instructions carefully during installation. In case of any confusion, please contact Pylontech immediately for advice and clarification (Contact information can be found on the back cover of the manual).

Explanation of Symbols

Symbol	Description
	Danger: Indicates a hazard with a high level of risk which, if not avoided, will result in death or serious injury.
	Warning: Indicates a hazard with a medium level of risk which, if not avoided, could result in death or serious injury.
	Caution: Indicates a hazard with a low level of risk which, if not avoided, could result in minor or moderate injury.
	Notice: Indicates a potentially hazardous situation which, if not avoided, could result in equipment damage, data loss, performance deterioration, or unanticipated results. NOTICE is used to address practices not related to personal injury.











Contents

Legal Information	I
About this Manual	II
Purpose	II
Explanation of Symbols.....	II
Contents	III
1 Safety	1
1.1 Symbols.....	1
1.2 Personal Requirements	2
1.3 General Safety	2
1.4 Safety Instructions Before Connecting the Battery.....	4
1.5 Safety Instructions in Using the Battery.....	4
2 System Introduction	5
2.1 Features.....	5
2.2 Battery Interface.....	6
2.3 Specifications.....	9
3 Safe Handling of Lithium Batteries	11
3.1 Schematic Diagram of Solution	11
3.2 Label.....	12
4 Installation	13
4.1 Checking Before the Installation.....	13
4.2 Preparing Tools and Instruments.....	14
4.3 Selecting the Installation Sites	15
4.4 Installation Direction.....	16
4.5 Installing the Batteries.....	18
4.5.1 Installing the Battery on the Floor.....	18
4.5.2 Installing the Battery on the Wall	22
5 Cable Connection	26
5.1 Checking Cables.....	26
5.2 Connecting the Grounding Cable.....	26

5.3	Single-string Cable Connection	27
5.4	Multi-string Cable Connection	29
5.5	Suitable Disconnection Device.....	30
6	Commissioning.....	31
6.1	System Turning On.....	31
6.2	System Turning Off.....	32
7	Display Panel Introduction	33
7.1	Main Screen.....	33
7.2	Setting.....	35
7.2.1	Device Info.....	35
7.2.2	General Setting.....	35
7.2.3	Advanced Setting.....	36
7.3	Alarm	39
8	Troubleshooting	40
9	Emergency Situations.....	44
10	Remarks	45
10.1	Recycle and Disposal.....	45
10.2	Storage, Maintenance and Expansion	45

1 Safety

1.1 Symbols

Icon	Meaning	Icon	Meaning
	Read the manual before installing and operating the product.		Do not connect the positive and negative reversely.
	General warning label indicating potential hazards.		Keep away from flame or ignition sources.
	Warning: electric shock.		Keep away from children.
	Warning: flammable materials.		Label for Waste Electrical and Electronic Equipment (WEEE) Directive (2012/19/EU).
	Warning: Do not touch the enclosure of the operating product.		The system meets the requirements of the applicable EU directives.
	The certificate label for Safety by TÜV SÜD.		

1.2 Personal Requirements

Qualified personnel must have the following skills:

- Training in the installation and commissioning of the electrical system, as well as the dealing with hazards.
- Knowledge of the manual and other related documents.
- Knowledge of the local regulations and directives.

1.3 General Safety

Declaration

This system is only operated by authorized personnel. Read all safety instructions carefully prior to any work and follow these instructions at all times when working with the system.

Incorrect operation or work may cause:

- Injury or death to the operator or a third party.
- Damage to the system hardware and other properties belonging to the operator or a third party.

General Requirements

DANGER

Danger: Batteries deliver electric power, resulting in burns or a fire hazard when short circuit or incorrect installment occurs.

DANGER

Danger: Lethal voltages are present in the battery terminals and cables. Severe injuries or death may occur if you touch the cables and terminals.

WARNING

Warning: DO NOT open or deform the battery module, otherwise the product will be out of warranty scope.

WARNING

Warning: Whenever operating the battery system, wear suitable personal protective equipment (PPE) such as rubber gloves, rubber boots and goggles.

 **WARNING**

Warning: For battery installation, the installer shall refer to NFPA70 or similar local installation standard for operation.

 **WARNING**

Warning: Pulling out the connectors while the system is working could lead to battery system damage or personal injury. Do not pull out the connectors while system is in operation.

 **CAUTION**

Caution: Improper settings or maintenance can permanently damage the battery.

 **CAUTION**

Caution: Battery needs to be recharged within 12 hours, after fully discharged.

 **CAUTION**

Caution: Risk of electric shock, do not remove cover. There is no user serviceable parts inside, refer servicing to qualified and accredited service technicians

 **WARNING**

Warning: Operations below must be accomplished by licensed technician or Pylontech authorized person.

1.4 Safety Instructions Before Connecting the Battery

CAUTION

Caution:

- After unpacking, please check product and packing list first, if the product is damaged or lack of parts, please contact the local retailer.
- Before installation, ensure to cut off the grid power and ensure that the battery is in the switched-off mode.
- Wiring must be correct, do not mistake the positive and negative cables, and ensure no short circuit with the external device.
- DO NOT connect the battery with AC power directly.
- The embedded BMS in the battery is designed for 51.2 VDC. DO NOT connect battery in series.
- Battery system must be well grounded and the resistance must be less than 100 mΩ.
- Please ensure the electrical parameters of battery system are compatible to related equipment.
- Keep the battery away from water and fire.

1.5 Safety Instructions in Using the Battery

CAUTION

Caution:

- If the battery is stored for long time, it is required to be recharged every six months, and the SOC should not be less than 50%.
- Battery needs to be recharged within 12 hours after being fully discharged.
- If the battery system needs to be moved or repaired, the power must be cut off and the battery is completely shut down in advance.
- DO NOT connect the battery with other different type of battery.
- DO NOT let the batteries work with faulty or incompatible inverter.
- DO NOT disassemble the battery (QC tab removed or damaged).
- In case of fire, only dry powder fire extinguisher can be used. DO NOT use liquid fire extinguishers.
- DO NOT open, repair or disassemble the battery unless by staff from Pylontech or authorized by Pylontech. We do not undertake any consequences or related responsibility due to violation of safety operation or violation of design, production and equipment safety standards.

2 System Introduction

2.1 Features

Pylontech Fidus Battery Plus is a low-voltage, high-capacity battery characterized by high integration, robust protection, and multiple functionalities. It is available in two versions: the standard FB-L-16 and the FB-L-16-Pro which includes low-temperature heating function for cold regions.



The following are the features of Fidus Battery Plus.

- Each 16kWh battery can deliver 10 kW of continuous power and handle 15 kW for short bursts (15 seconds).
- Features a built-in display panel, providing direct access to essential real-time operational data and enabling on-device configuration of fundamental parameters.
- The built-in Bluetooth and Wi-Fi modules enable comprehensive monitoring and management, offering local connectivity via Bluetooth for the mobile app as well as full remote access for real-time status monitoring, control, and parameter configuration from any location once the unit is connected to a local network.
- Allows users to set custom charge and discharge limits according to actual needs and maximize battery life.
- Strong environmental adaptability with IP65 protection design, applied in outdoor or high humidity scenarios.
- Supports both floor-standing and wall-mounted installations. A wheel accessory is available as an option to facilitate movement for floor-standing installation, while a wall bracket accessory is used for wall-mounted installation.
- Up to 20 batteries in parallel can be supported in single string, up to 6 strings of batteries can be expanded to parallel use.
- Supporting CAN/485 two forms of communication; Upgrading battery module through CAN or 485 communication; Support remote upgrade.
- The FB-L-16-Pro model supports a low-temperature heating function, allowing users to customize the battery heating parameters via the APP or the display panel.

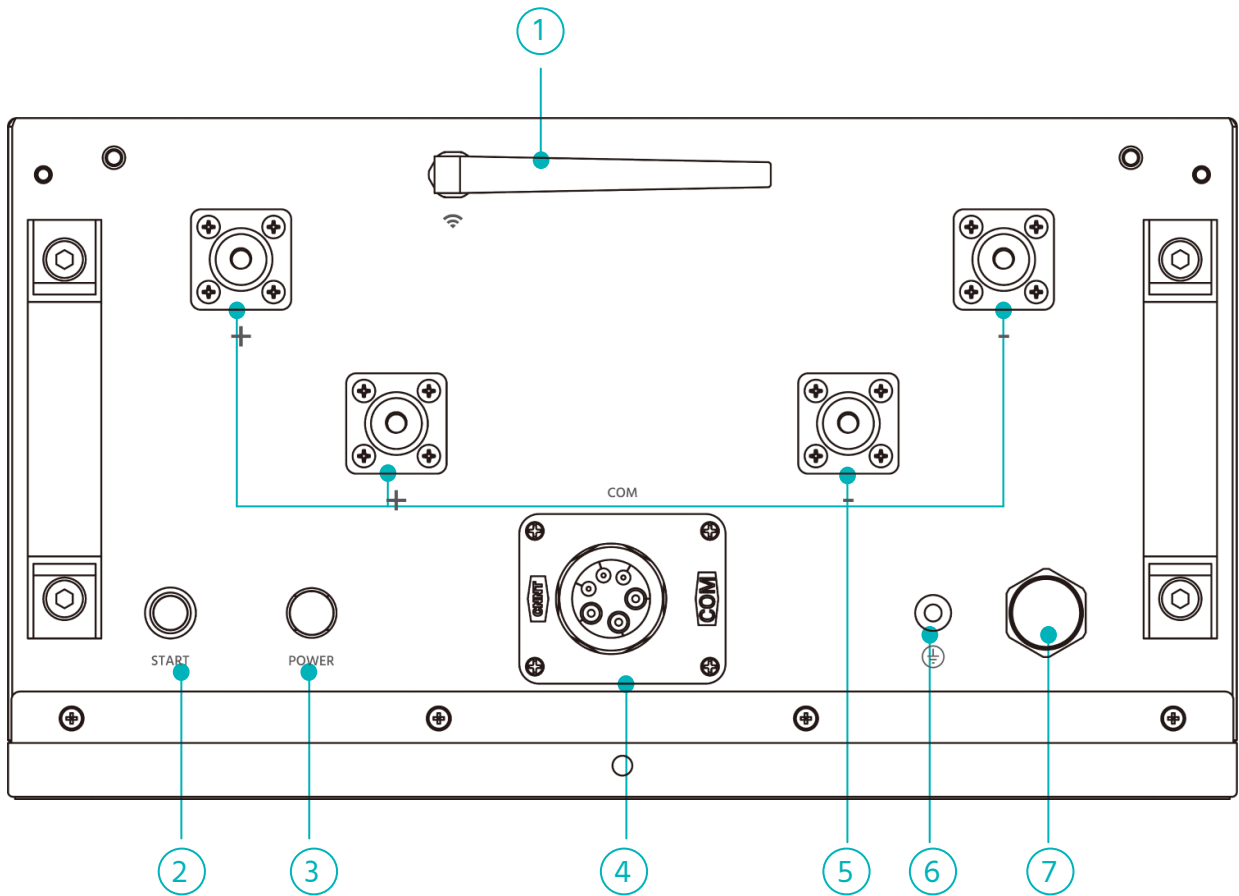
2.2 Battery Interface

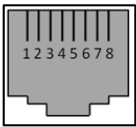

No.	Name	Description
1	Wi-Fi	<p>Built-in Wi-Fi module antenna for internet connectivity</p> <p>For more details, please scan the QR code provided to access the Pylontech RESS_Wi-Fi Portal Introduction.</p> 
2	Start button	Turn On/Off the System

No.	Name	Description																
		<ul style="list-style-type: none"> After powering on, short press the START button to start the device. Hold the START button for 5 seconds to shut down the device. 																
3	Power button	<ul style="list-style-type: none"> Press the POWER button to turn on the system. Press the POWER button again to turn off the system. <p>NOTE: Please keep the battery powered off during storage or transportation.</p>																
4	Communication Terminals	<p>Before connecting the communication terminals, loosen the 4 screws on the cover as follows, then you will see the communication terminals.</p> <ul style="list-style-type: none"> RS485: 9600 or 115200 bps. CAN: 500 Kbps. <table border="1" data-bbox="549 987 871 1424"> <thead> <tr> <th>PIN</th> <th>CAN/RS485</th> </tr> </thead> <tbody> <tr> <td>Pin1</td> <td rowspan="3">/</td> </tr> <tr> <td>Pin2</td> </tr> <tr> <td>Pin3</td> </tr> <tr> <td>Pin4</td> <td>CAN-H</td> </tr> <tr> <td>Pin5</td> <td>CAN-L</td> </tr> <tr> <td>Pin6</td> <td>CAN-GND</td> </tr> <tr> <td>Pin7</td> <td>485A</td> </tr> <tr> <td>Pin8</td> <td>485B</td> </tr> </tbody> </table> <div style="display: flex; justify-content: space-around; align-items: center;">   </div> <p>Link port 0/Link port 1: For communication between multiple parallel batteries.</p>	PIN	CAN/RS485	Pin1	/	Pin2	Pin3	Pin4	CAN-H	Pin5	CAN-L	Pin6	CAN-GND	Pin7	485A	Pin8	485B
PIN	CAN/RS485																	
Pin1	/																	
Pin2																		
Pin3																		
Pin4	CAN-H																	
Pin5	CAN-L																	
Pin6	CAN-GND																	
Pin7	485A																	
Pin8	485B																	
5	Power terminal(s)	There are two pair of terminals with same function, one is connected to equipment, the other is connected in parallel to other battery modules for capacity expansion.																
6	Grounding point	To connect the grounding cable.																
7	Explosion-proof valve	To balance the air pressure inside and outside the battery																

Communication Terminals

Before connecting the communication terminals, loosen the 4 screws on the cover as follows, then you will see the communication terminals.

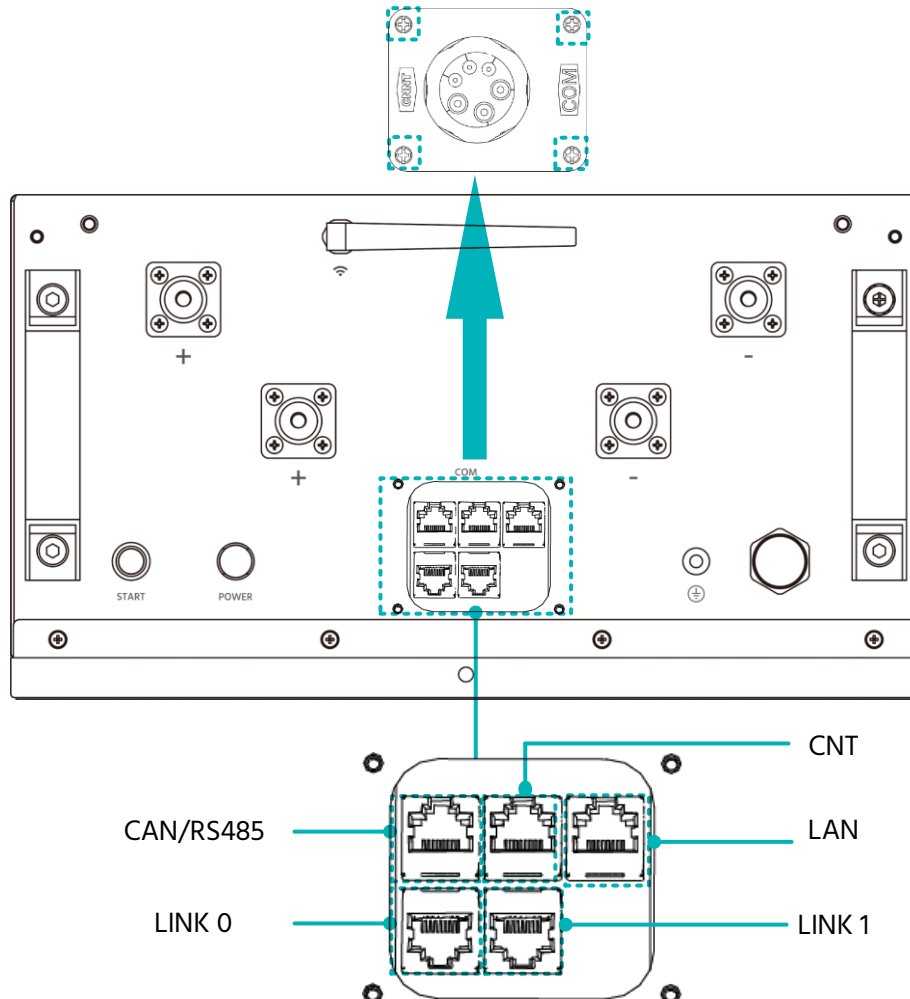

- **CAN/485:** Used for connecting to the PCS communication port (the communication mode with PCS needs to be confirmed).
- **CNT:** Water Ingress Sensor Interface.
- **LAN:** Supports Ethernet cable connection and delivers more stable signal transmission compared to the built-in WIFI module.
- **LINK0/LINK1:** Used for parallel connection between batteries; see *Chapter 4 Installation* for more details.

2.3 Specifications

Specifications	FB-L-16	FB-L-16-Pro
Nominal Voltage (VDC)	51.2	
Nominal Capacity (Wh)	16076	
Usable Capacity (Wh)	16076	
Depth of Discharge (%) *	100	
Dimensions (mm)	435(W) × 240 (D) × 900(H)	
Weight (Kg)	120±2	122±2
Discharge Voltage (VDC)	42.5~57.6	42.5~57.6
Charge Voltage (VDC)	56.8 ~ 57.6	
Maximum Continuous Charge/Discharge Current (A)	188/200	
Peak Charge/Discharge Current (A)	300A @ 15 seconds	
Communication	RS485, CAN	
Configuration (maximum quantity in one battery group)	20	
Configuration (maximum strings) **	6	
Working Temperature (°C) ***	Charging: 0~55 discharging: -20~55	-20~55
Storage Temperature (°C)	-20 ~ 60	
Short Current/Duration Time (A/1ms)	< 1,000 A/1ms	
Cooling Type	Natural	
Protective Class	I	
IP Rating of Enclosure	IP65	
Anti-corrosion	C5-M	
Humidity (% RH, No Condensation)	5 ~ 95	
Altitude(m)	≤ 4000	
Certifications	IEC62619, IEC63056, UN38.3, EMC/CE	
Design Life (year) (25°C /77°F)	10	
Cycle Life (25°C /77°F) ***	8000	
Interaction	Display panel, Bluetooth and WI-FI(Optional)	

*: The battery supports 100% DoD operation and can deliver the rated capacity at 25°C @ 0.2C. The default SOC lower limit is 5%, which can be adjusted as needed.

**: When installing multiple batteries, the LV-HUB-V2 product is required to enable parallel connection of multiple batteries. The LV-HUB-V2 serves as the master unit, with a maximum of 19 batteries per group.

***: In low and high temperature section, BMS will reduce the recommended current and need to be used with reduced power; In the range of -20°C to 0°C, charging is permitted after the battery

temperature is raised above 0°C via the heating function.

** : 25°C/0.2C, for details, please seek technical support from PylonTech.

3 Safe Handling of Lithium Batteries

3.1 Schematic Diagram of Solution

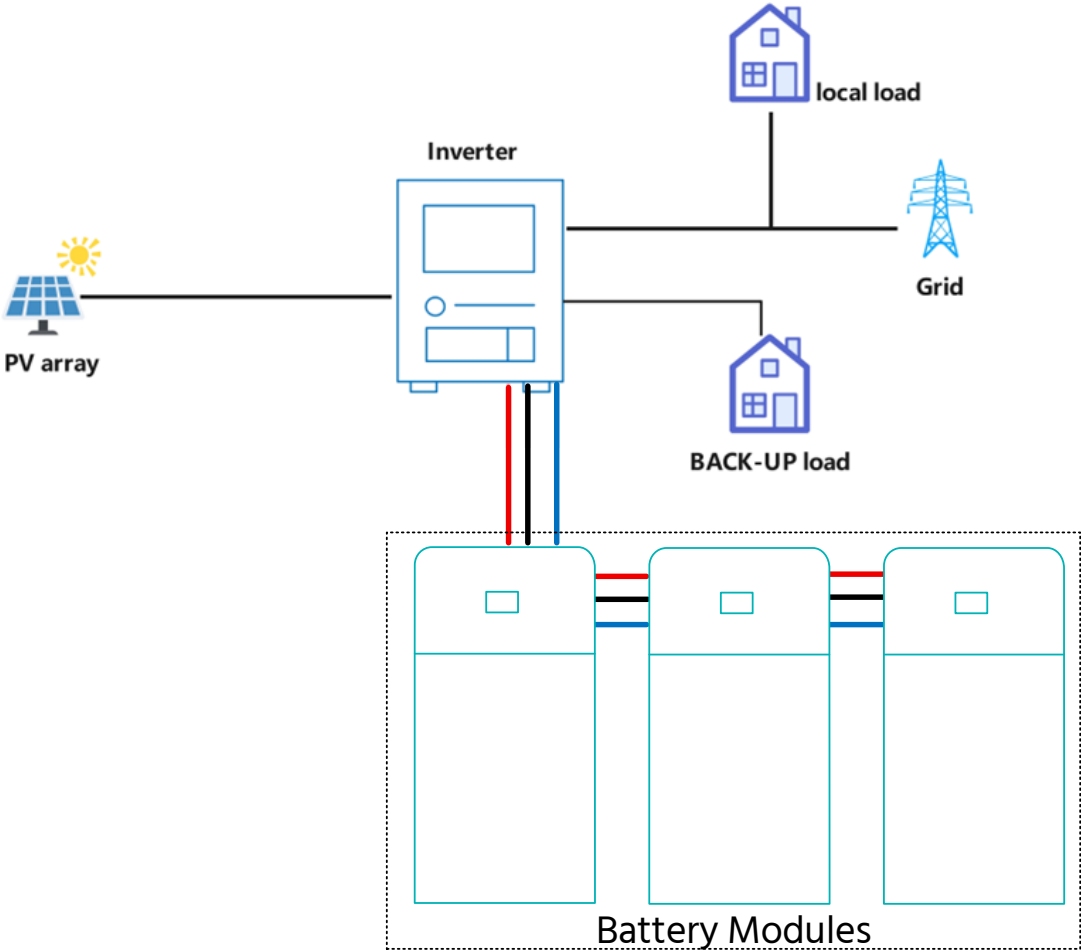

3.2 Label





Rechargeable Li-ion Battery

Battery Designation:	IFpP73/176/208[16S]M/0+50/95
Battery Category:	Industrial Battery
Model:	FB-L-16-0110
Part Number:	11FB16000ZA-20000
Rated Energy/Capacity:	16.07kWh/314Ah
Nominal Voltage:	51.2Vd.c.
Recommended Charge Voltage:	57.6Vd.c.
Maximum Charging/Discharging Current:	188A/200A
Short Current/Duration:	< 1000A/1ms
Protection Class:	I
IP Rating:	IP65
Weight:	120±2kg
Chemistry:	LiFePO ₄ /LiPF ₆ /Graphite
Critical Raw Materials:	LiFePO ₄ /LiPF ₆ /Graphite
Hazardous Substances:	/
Usable Extinguishing Agent:	A/B/C/F
Charge Temperature:	0~55°C
Discharge Temperature:	-20~55°C

The date of manufacture:
SN: H250825C70010001

Registration











Manual

Pylon Technologies Co., Ltd. | www.pylontech.com.cn
No.300, Miaoqiao Road, Kangqiao Town, Pudong New Area, Shanghai 201315, China
The place of manufacture: Intersection of Daqianshan Road and Gaocheng Road, Economic Development Zone, Feixi County, Hefei 231299, Anhui Province, China

⚠ DANGER DANGER LOW DC VOLTAGE INSIDE
DANGER TENSION BASSE À L'INTÉRIEUR
DANGER ARC FLASH & SHOCK HAZARD
DANGER D'ARC ÉLECTRIQUE ET DE RISQUE D'ÉLECTROCUTION

- 
 - * Do not disconnect, disassemble or repair by yourself.
Ne pas débrancher, démonter ou réparer soi-même.
- 
 - * Do not drop, deform, impact, cut or spear with a sharp object.
Ne pas échapper, déformer, frapper, couper ou transpercer avec un objet pointu.
- 
 - * Do not place near open flame or incinerate.
Ne pas placer près des flammes nues ou incinérer.
- 
 - * Do not sit or put heavy things on battery.
Ne pas s'asseoir ou mettre des objets lourds sur la batterie.
- 
 - * Keep away from moisture or liquid.
Tenir loin de l'humidité ou de tout liquide.
- 
 - * Keep out of reach of children, animals or insects.
Garder hors de la portée des enfants, des animaux ou des insectes.
- 
 - * Contact your supplier within 24 hours if anything failure happens.
Contactez votre fournisseur dans les 24 heures en cas de panne.

CAUTION
Lift Only By The Handle Behind

**Remove The Protective Film
After Installation**

4 Installation

CAUTION

Caution: According to local electric safety and installation policy, a suitable disconnection device between battery system and inverter could be installed.

All the installation and operation must follow local electric standards.

4.1 Checking Before the Installation

Checking the Outer Packing and Deliverables

- After receiving the product, check the outer packing for damage, such as holes, cracks, deformation and so on. If any damage is found, contact the local retailer as soon as possible.
- After unpacking the product, check that the deliverables are complete. If any item is missing or damaged, contact the local retailer as soon as possible.

CAUTION



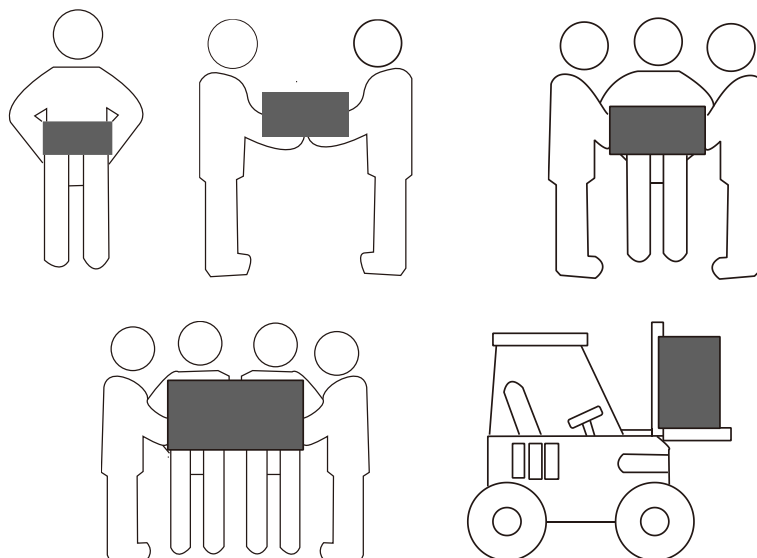



Caution: Moving heavy objects. Be careful to prevent injury when moving heavy objects. Select an suitable way to moving heavy objects according to product weight.

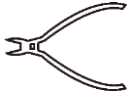
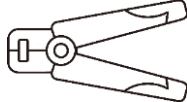
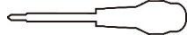
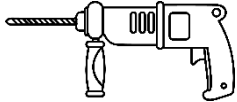

Weight	Method	Recommendation
< 18 kg	Manual handling	1 person
18 ~ 32 kg	Manual handling	2 persons
32 ~ 55 kg	Manual handling	3 persons
55 ~ 68 kg	Manual handling	4 persons
> 68 kg	Moving device	Forklift

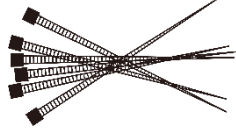
4.2 Preparing Tools and Instruments

Tools and Instruments

Type	Tools and Instruments		
Installation			
	Wire Cutter	Crimping Plier	Screwdriver
			
	Hammer Drill	Socket Wrench Set	Cable Ties
Personal protective equipment (PPE)			
	Insulated Gloves	Safety Goggles	Safety Shoes
			
	Anti-arc Flash Suit		

NOTE: Use properly insulated tools to prevent accidental electric shock or short circuits. If insulated tools are not available, cover the entire exposed metal surfaces with available insulated alternatives, except their tips, with electrical tape.

4.3 Selecting the Installation Sites

Working Environment Requirements

CAUTION

Caution:

If the ambient temperature is out of the operating range, the battery stops working to protect itself. The optimal temperature range for the battery module operation is 15 °C to 40 °C.

Frequent exposures to harsh temperatures may deteriorate the performance and life of the battery.

Ensure that the installation location meets the following conditions:

- Ensure that the battery is not soaked in water.
- The floor is flat. Or if the wall is strong enough to support the battery wall mounting.
- There are no flammable or explosive materials.
- The ambient temperature is within the range from 0 °C to 50 °C.
- There is minimal dust and dirt in the area.
- The distance from heat source is more than 2 meters.
- The distance from air outlet of inverter is more than 0.5 meters.
- The installation areas should be protected from direct sunlight.
- There are no mandatory ventilation requirements for the battery module, but please avoid of installation in confined area.
- Do not place heavy objects on top of the battery after installation, and it is recommended to set up isolation in the battery installation area to avoid dropping the battery and hitting people or animals.
- This product supports offshore installation, with the installation location required to be at least 500 meters from the coastline. Within 1 kilometer of the coastline, obstacles must be placed directly in front of the battery (facing the coast) to prevent direct sea breeze on the battery surface; beyond 1 kilometer, no obstacles are needed for installation.

4.4 Installation Direction

Recommended:

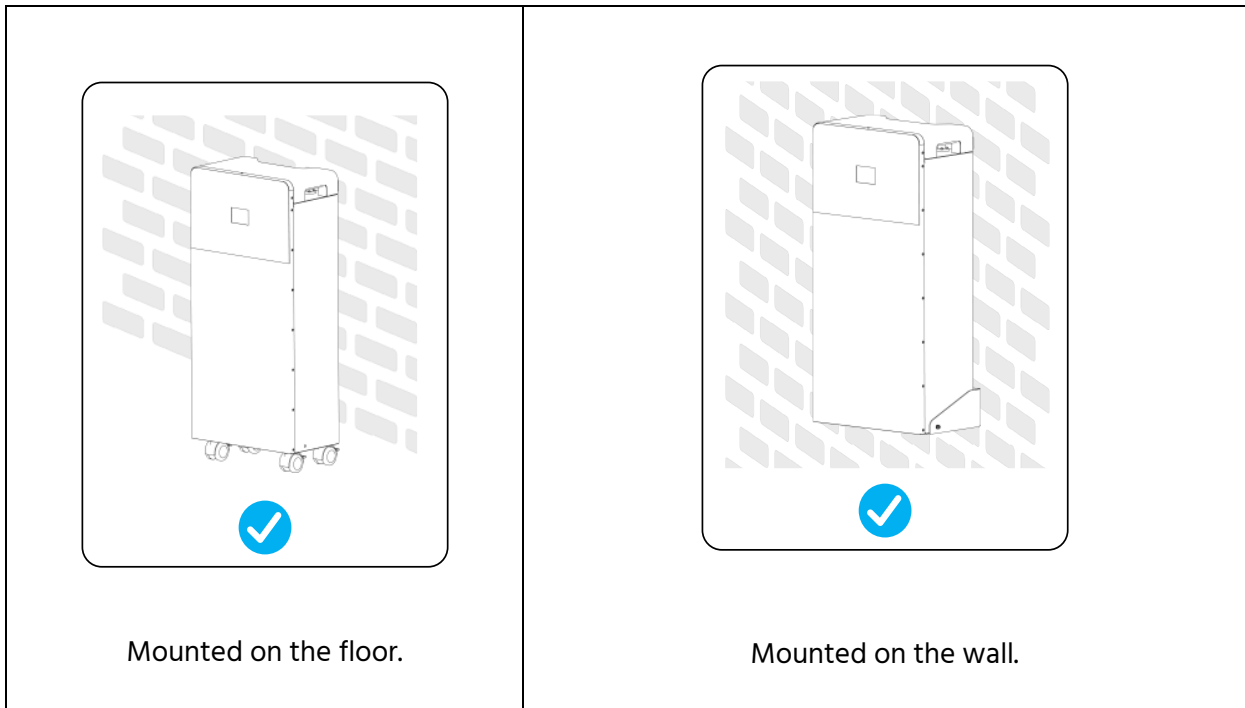

NOTE:

The wall must possess **adequate load-bearing capacity** to support the installation.

NOT allowed:

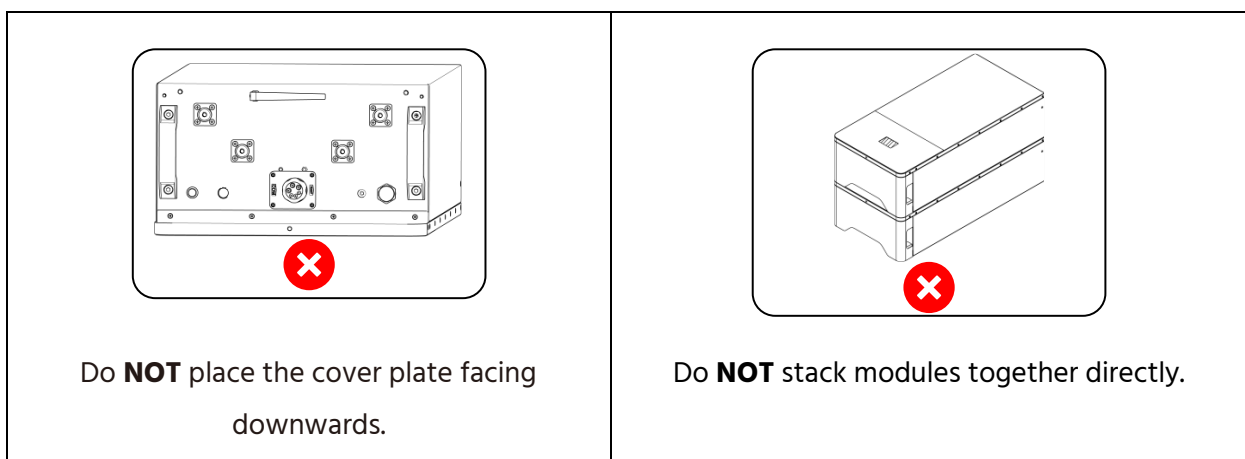

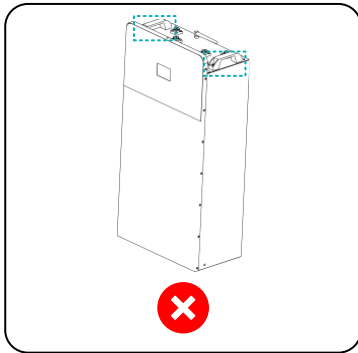

Do **NOT** hang the module by the handles.

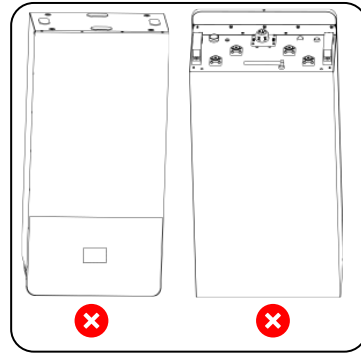

Do **NOT** put the module in the reverse position.

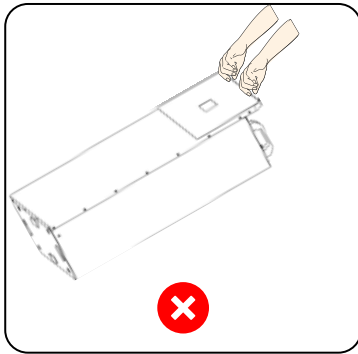

Do **NOT** lift the module by its front panel.

4.5 Installing the Batteries

There are 2 installation methods for battery modules based on different usage preferences.

4.5.1 Installing the Battery on the Floor

Procedure

1. Hold the handles to remove the battery from the enclosure.
2. Place the battery horizontally on the installation surface.

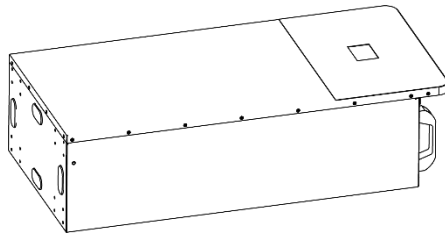

3. Secure four casters using 16 M5 × 12 expansion bolts (tightening torque: 3.5 Nm).

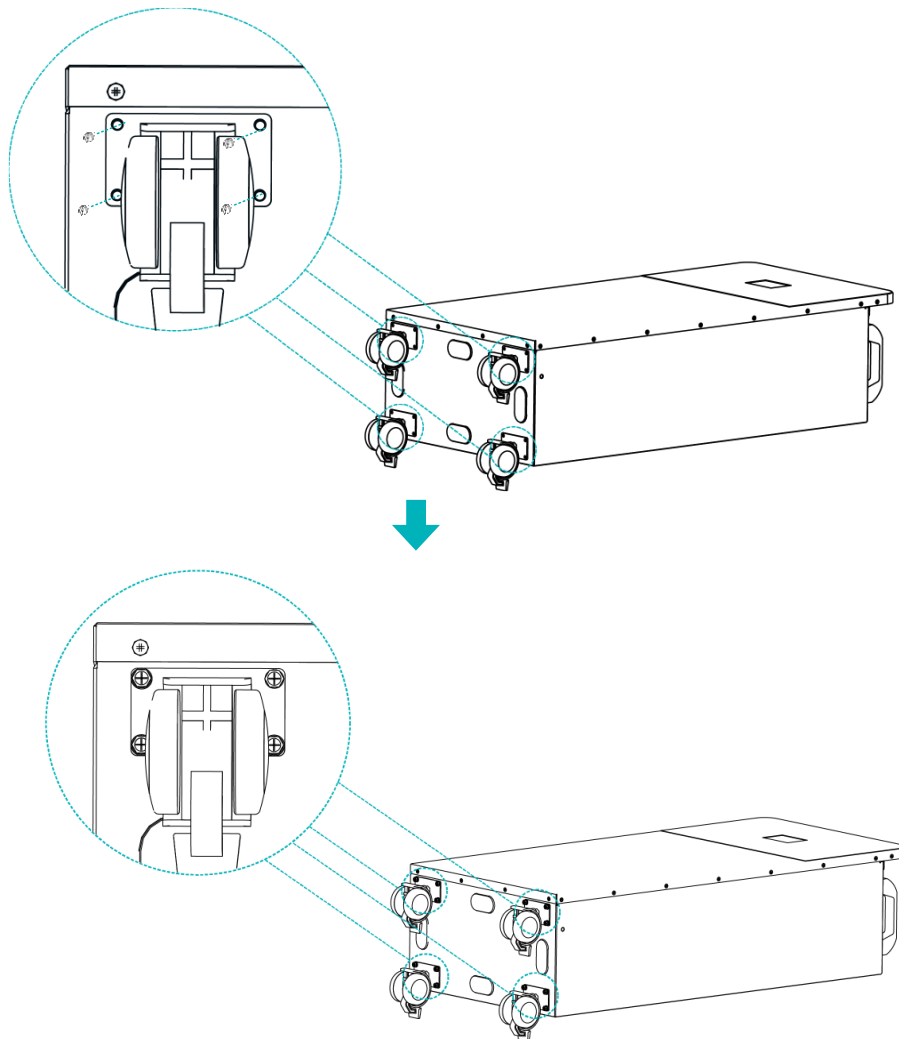

4. Hold the handles and lift the battery to move it into position against the wall.

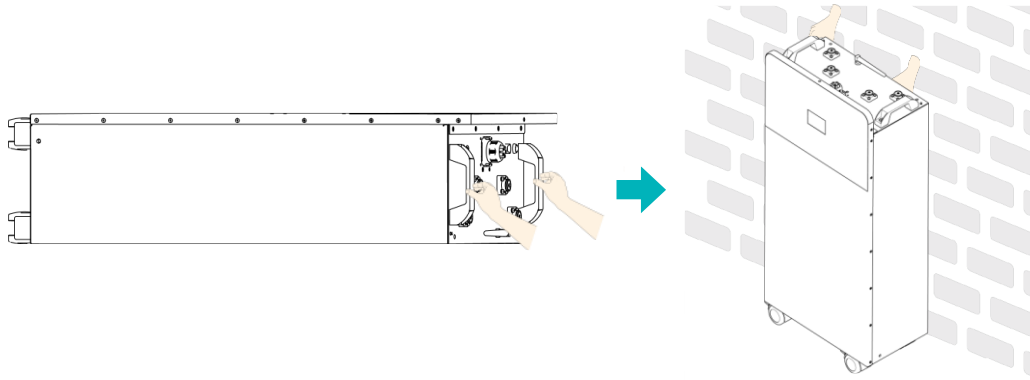

5. Use 2 M6 × 14 screws to mount the bracket above onto the battery module.

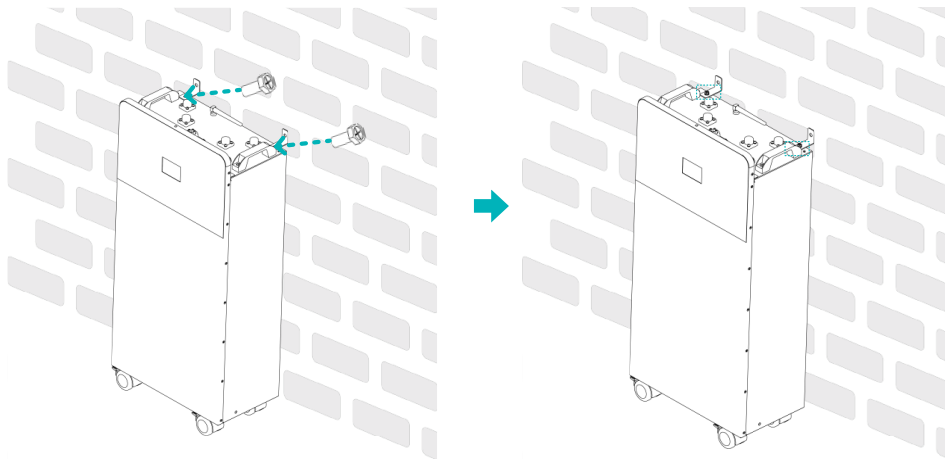

6. Mark the positions for drilling holes corresponding to those on the wall bracket.

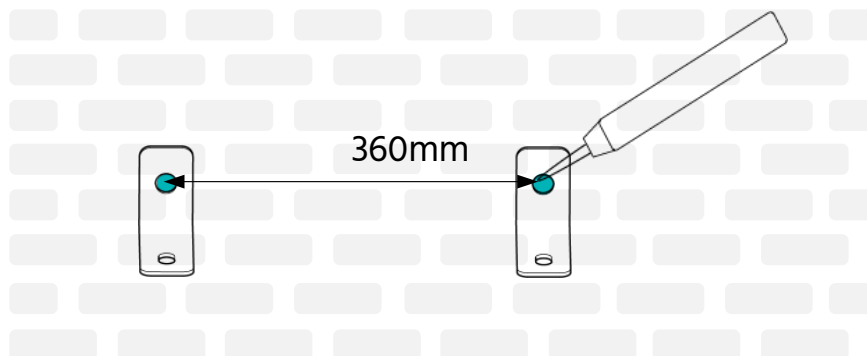

7. Drill holes to a depth of 80 mm using the hammer drill.

The diameter of the drill bit should be 10 mm.

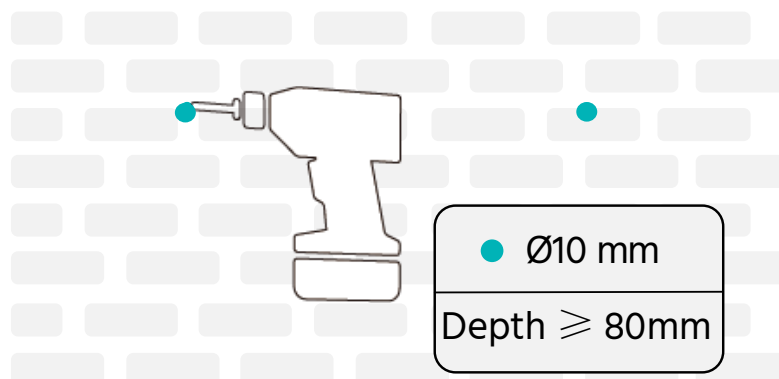

- Secure the wall bracket using 2 M8 × 60 expansion bolts.

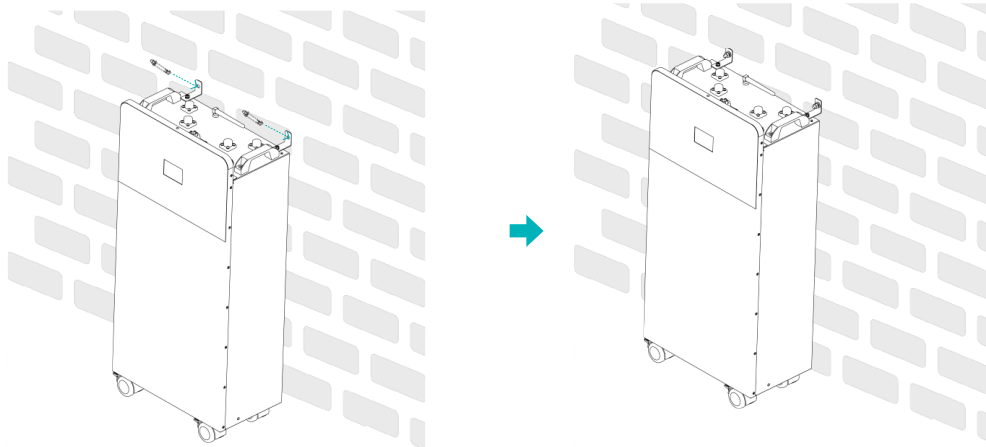

- Lock the wheels by pushing the pin downward.
- Connect the cables (see *Chapter 5 Cable Connection*).
- Install the cover onto the battery.

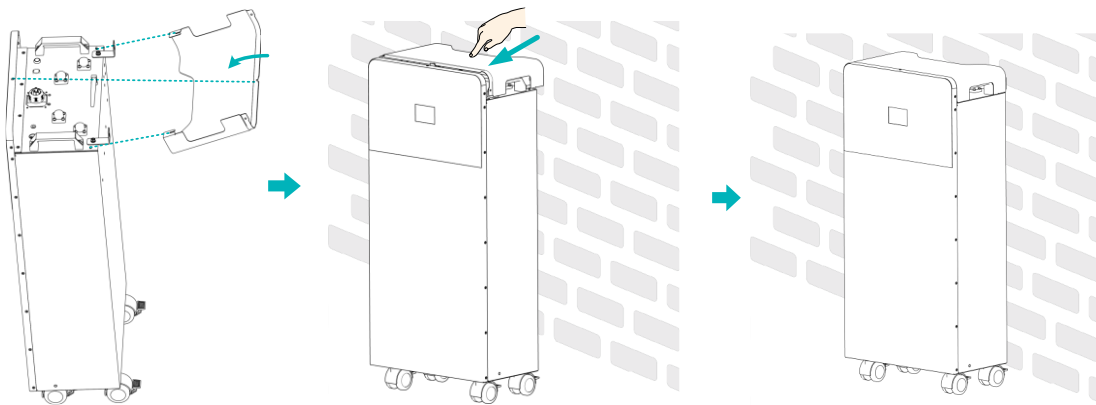

- Repeat step 1 ~ step 11 above if more than 2 batteries need to be installed.

NOTE: When installing multiple batteries, a minimum spacing of 500 mm shall be maintained between each battery.

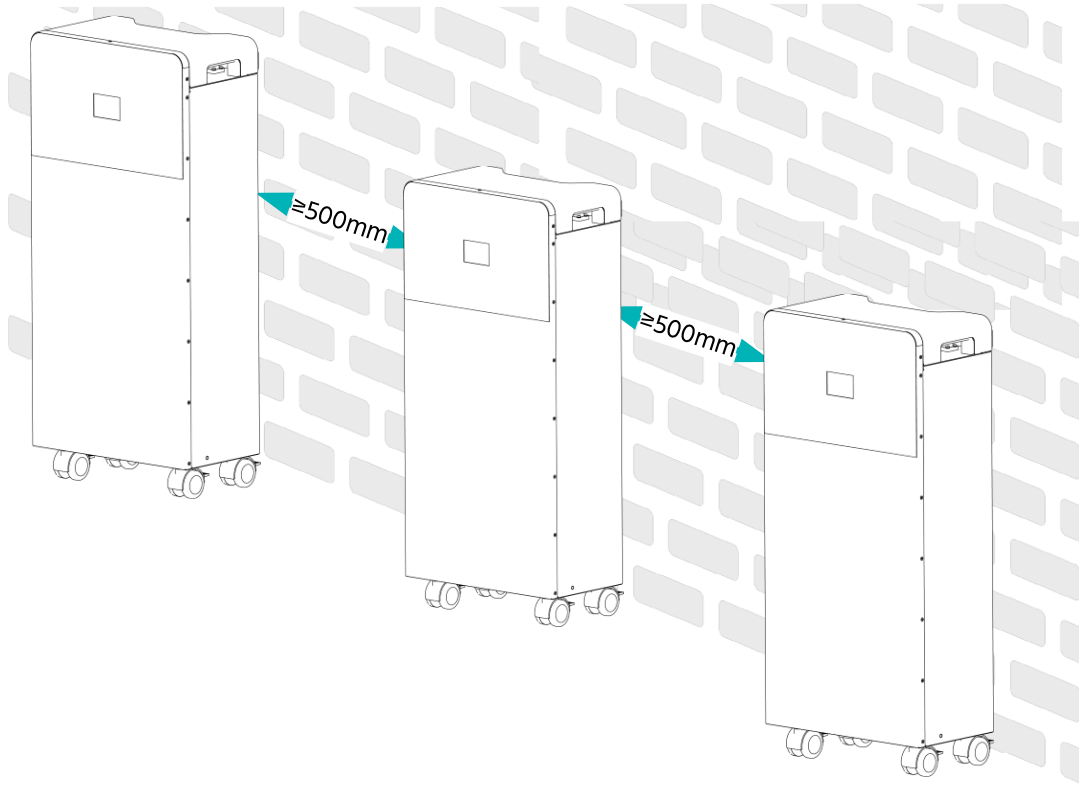

4.5.2 Installing the Battery on the Wall

1. Put the wall bracket on the wall horizontally and mark positions for drilling holes.

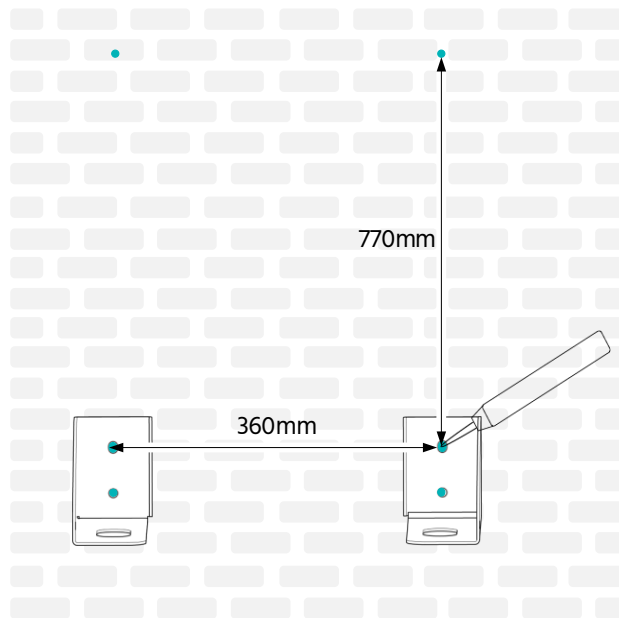

2. Drill holes to a depth of 80 mm using the hammer drill.

The diameter of the drill bit should be 10 mm.

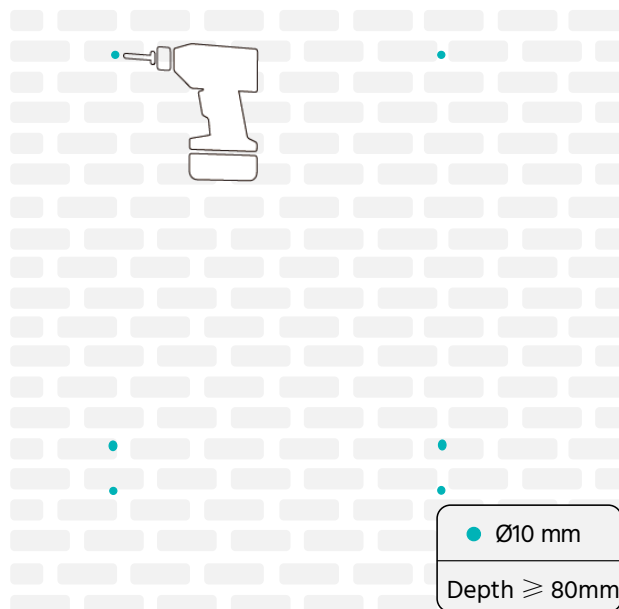

3. Secure the wall bracket using 4 M8 × 60 expansion bolts.

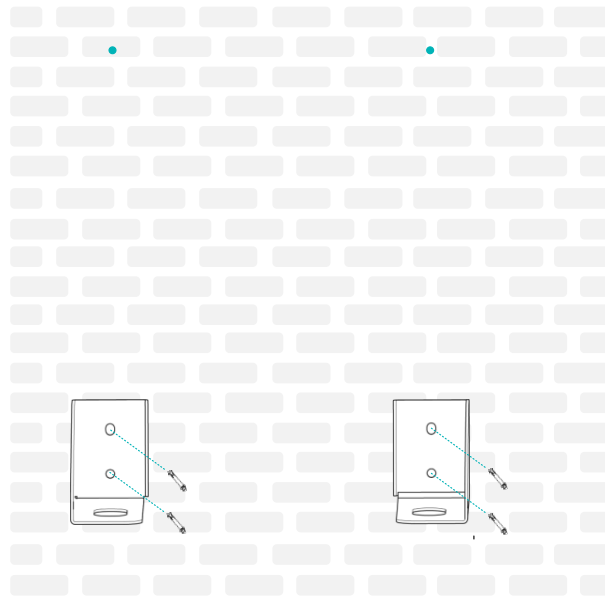

4. Lift the battery using a forklift or lifting equipment and adjust to keep the bottom of the battery align with the wall brackets, and slowly put down the battery to fit it properly on the wall brackets.

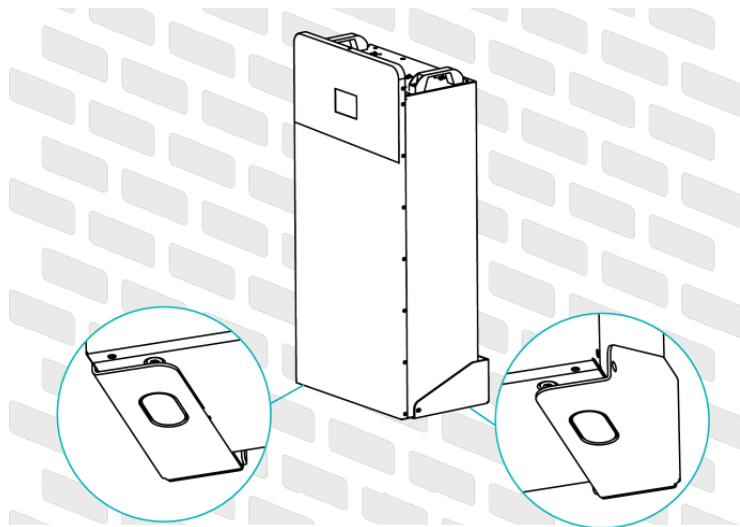

5. Use 2 M6 × 14 screws to fasten the battery to the wall brackets on the both sides of the battery (tightening torque: 5 Nm).

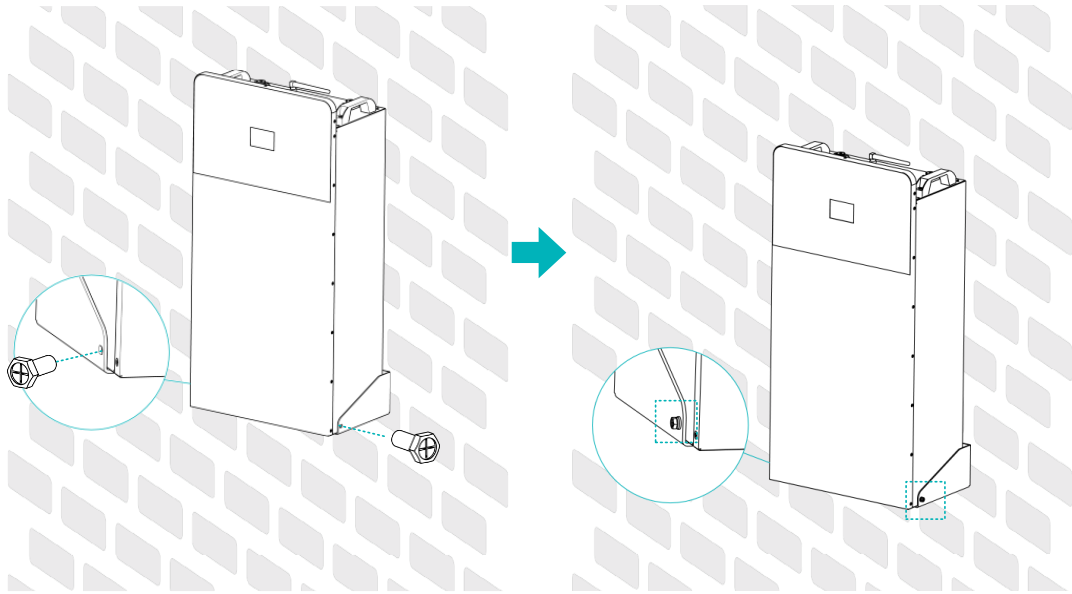

6. Use 2 M6 × 14 screws to mount the bracket above onto the battery module.

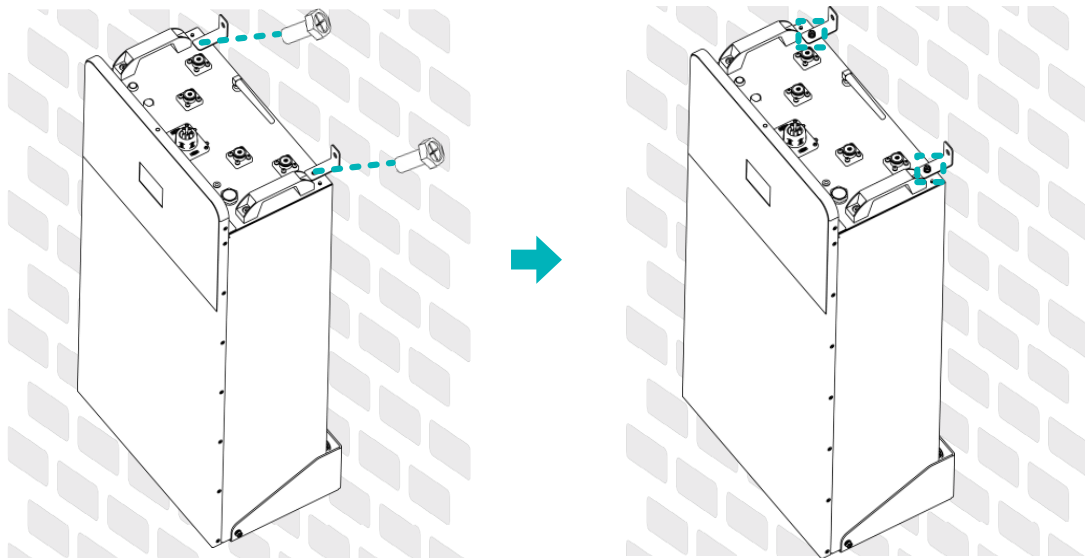

7. Secure the wall bracket using 2 M8 × 60 expansion bolts.

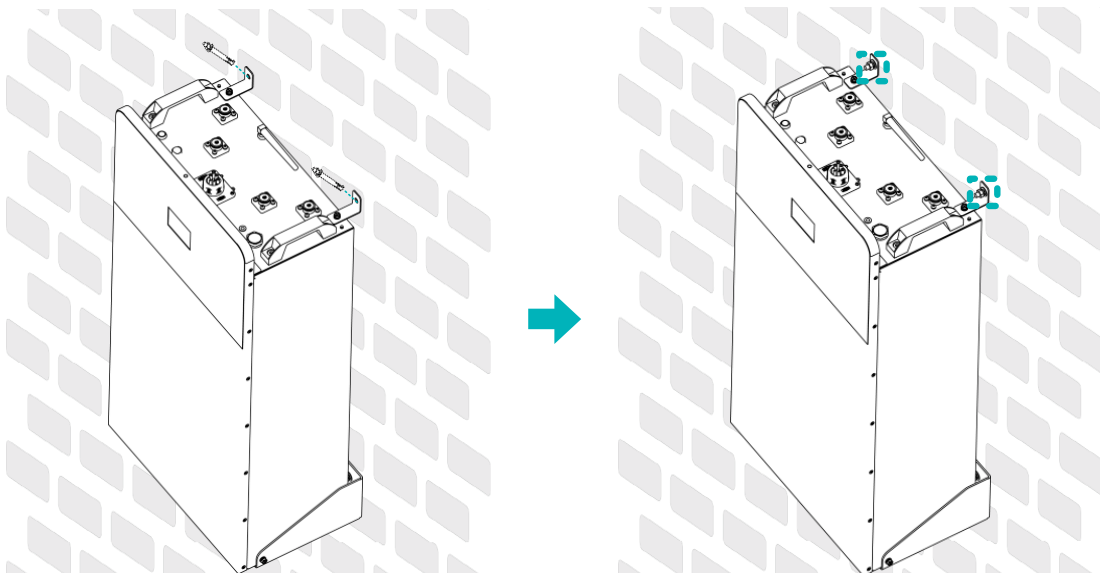

8. (If any) Repeat the step 1 to step 7 above if more than one battery needs to be installed.
9. Connect the cables (see *Chapter 5 Cable Connection*).
10. Install the cover onto the battery.

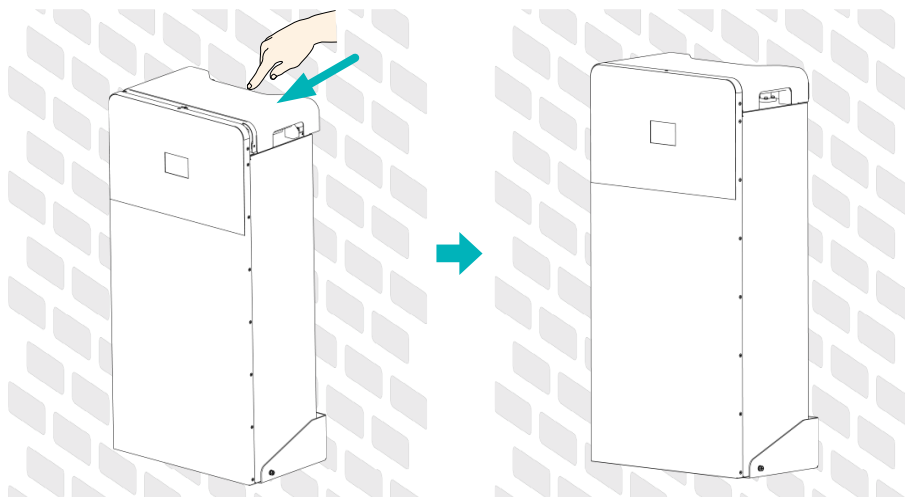
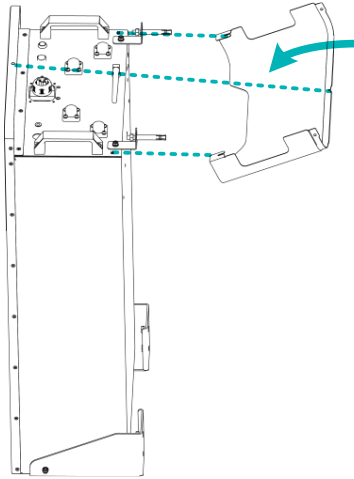

NOTE: When installing multiple batteries, a minimum spacing of 500 mm shall be maintained between each battery.

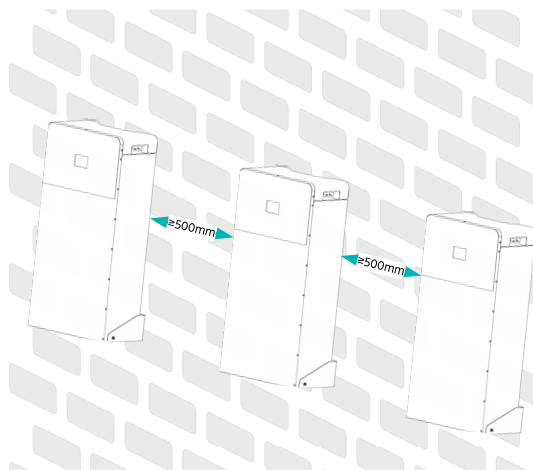

5 Cable Connection

5.1 Checking Cables

AWG	Maximum Current	Recommended Current
1/0 AWG	250 A	200 A

5.2 Connecting the Grounding Cable

Grounding cables should be 6 AWG or higher yellow-green cables. After connection, the resistance from battery grounding point to Ground connection point of room or installed place should be less than 0.1 Ω.

Procedure

1. Connect a grounding cable to the grounding point of the modules.

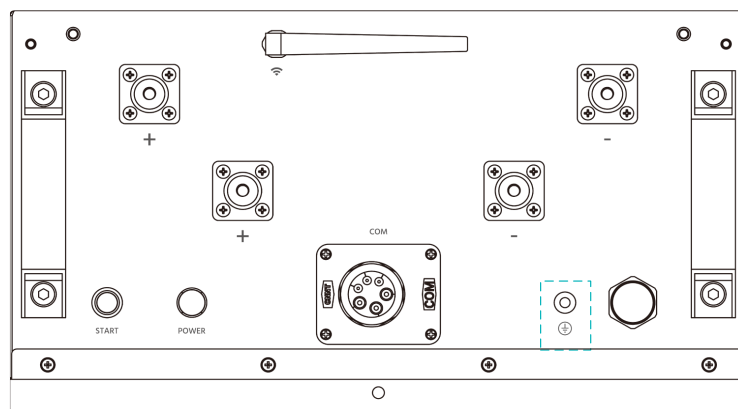

2. Grounding cables are required for inter-module connection when multiple modules are in use.

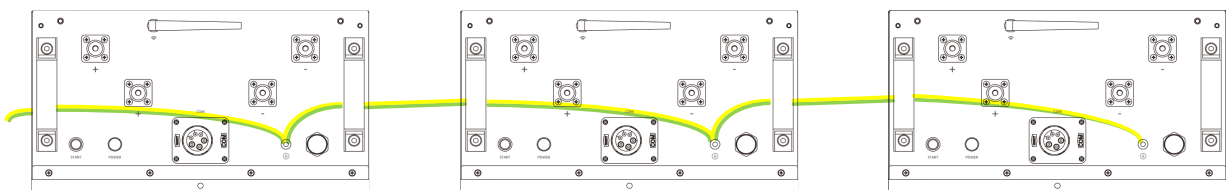

5.3 Single-string Cable Connection

Procedure

1. Connect the power cables and communication cables between batteries.
2. Connect the power cable and communication cable to the inverter.

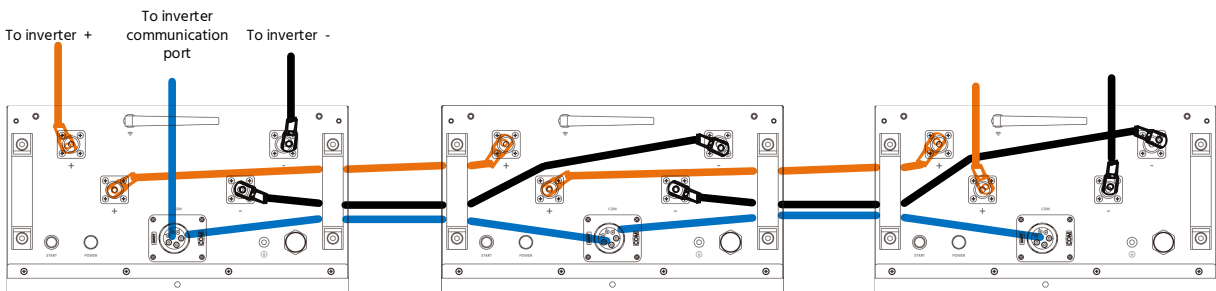
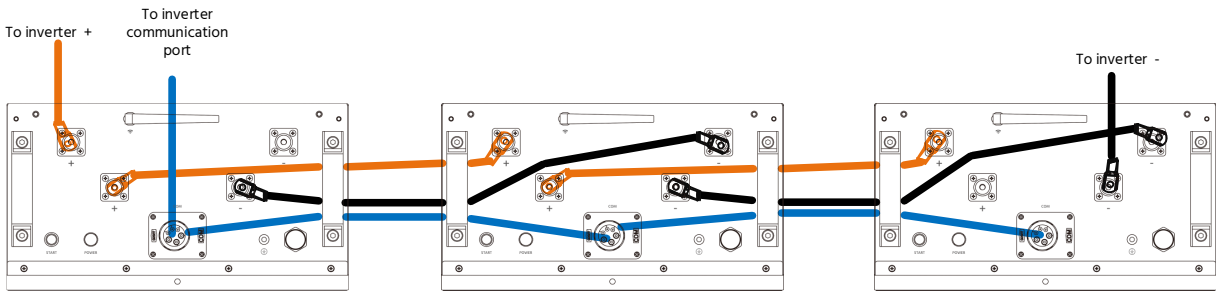
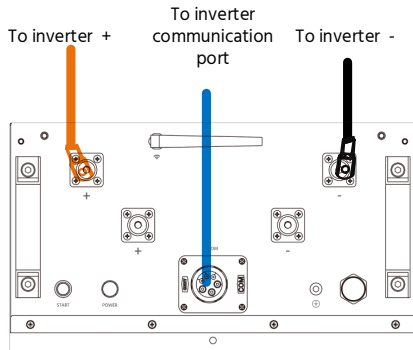

Communication cable connection

The communication for master/slave battery connection shall use an 8 pin RJ45 cable, connecting from the first battery Link 1 to the second battery Link 0, then from the second battery Link 1 to third battery link 0(if has), all the way to the last battery Link 0.

The battery with Link 0 EMPTY is defined as the Master battery. Select either CAN or RS485 on the master battery for further connection with the inverter or upper controller.

The CAN/RS485 Port of the slave battery is ineffective in this case.

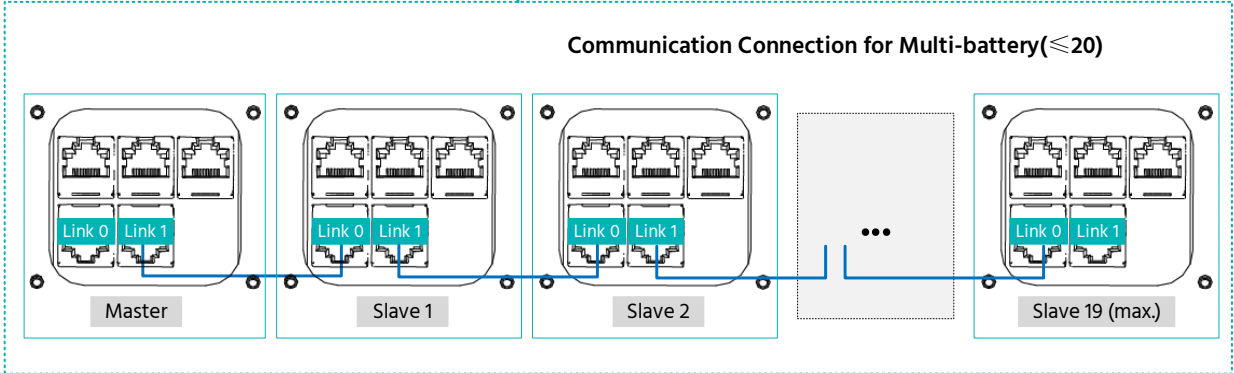
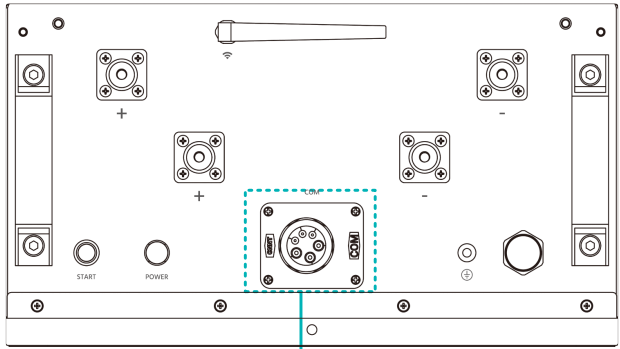

5.4 Multi-string Cable Connection

Power cable connection



Communication cable connection

NOTE: For parallel application of multiple batteries, LV-HUB-V2-Pro product is required.

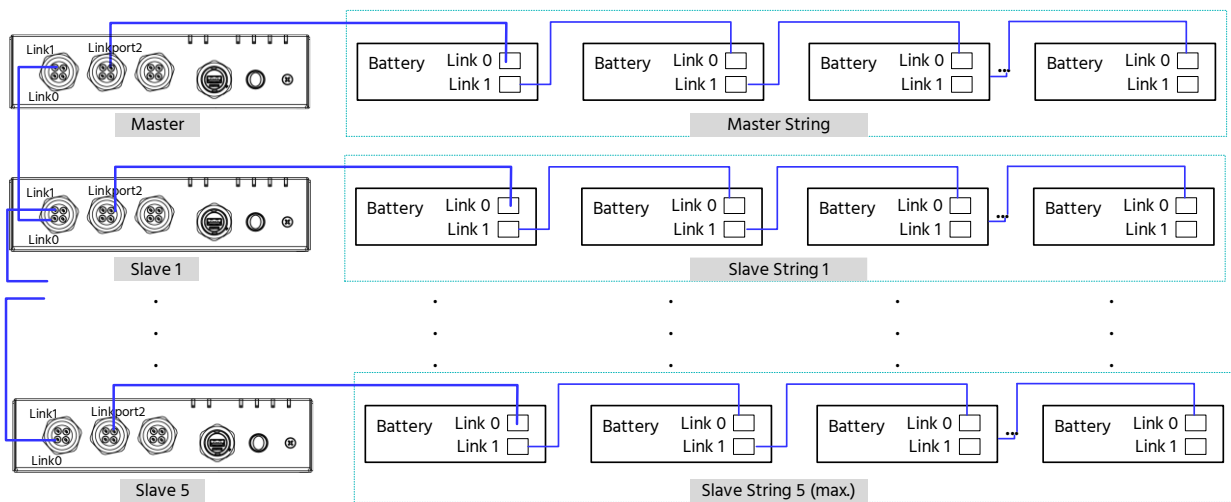

NOTE: After installation, DO NOT forget to register online to activate warranty:

www.pylontech.com.cn/service/support.

5.5 Suitable Disconnection Device

It is recommended to have a disconnection device for protection between battery system and inverter:

1. The rated voltage should be $\geq 60\text{VDC}$. Use a DC breaker.
2. The rated current should match with system design:

The following factors shall be considered:

- The maximum DC current on inverter side.
 - The number of power cable: for instance, if there is only one pair of 1/0 AWG cable, the rated current of breaker shall be $\leq 250\text{ A}$.
3. If using a breaker, it shall be type C (recommended) or type D.

The Icu required: the maximum short circuit current for calculation of each module is 1000 A.

For instance:

Battery amount	Icu of breaker
1~4 modules	Must $\geq 4\text{ kA}$
5~8 modules	Must $\geq 8\text{ kA}$

6 Commissioning

6.1 System Turning On

Double-check all power and communication cables between batteries, and between battery and inverter. Once confirmed connected correctly, close the circuit breaker between the battery and the inverter (if any).

Procedure

1. Power on all the battery modules.

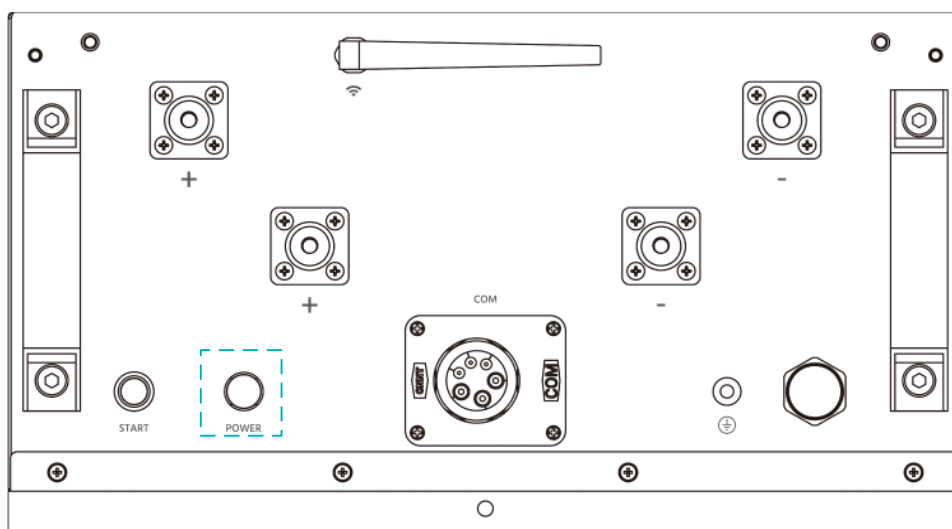

The one with **empty Link Port 0** is the **master battery**, others are slaves (1 master battery configuring maximum 19 slave batteries).

2. Press the **red start button** of **master battery** to turn on. After the master battery LED turns on, the LEDs on all the slave batteries will be on in sequence.

NOTE:

- After the battery module is powered on, the pre-charging circuit will continue to work for 3 seconds. Once the precharge is complete, the battery is ready for high power output.

NOTE: Restart the battery 2 to 3 times if precharge fails.

- When connecting modules with different SOC/voltage in parallel during expansion or replacement, it is recommended to maintain the system in IDLE for ≥ 15 minutes or till the SOC LEDs become similar (≤ 1 dot difference) before normal operation.

6.2 System Turning Off

Procedure

1. Turn external power source off.
2. Press the Start button of the master battery for 5 seconds, then release it, and all batteries will be turned off.

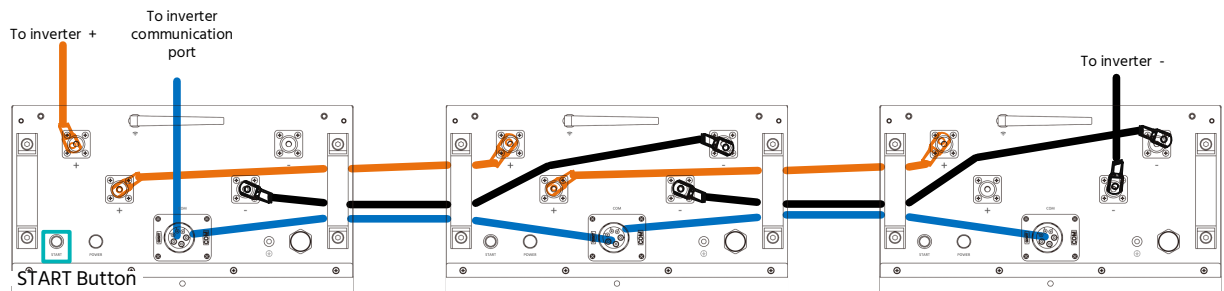

3. Turn Power Button to OFF on master battery and all slave batteries.
4. Disconnect the circuit breaker between the battery and the inverter (if any).

7 Display Panel Introduction

The FB-L-16 battery features an integrated display panel, allowing users to view basic operating status and parameter settings via touch operation. The panel, which has no physical buttons, remains in sleep mode during normal operation. It can be activated instantly by touching the panel when information access is required.

7.1 Main Screen

Upon activation, the panel presents the main screen. This screen displays key operational parameters, including battery voltage, current, State of Charge (SOC), and battery status (Idle, Charging, Discharging).

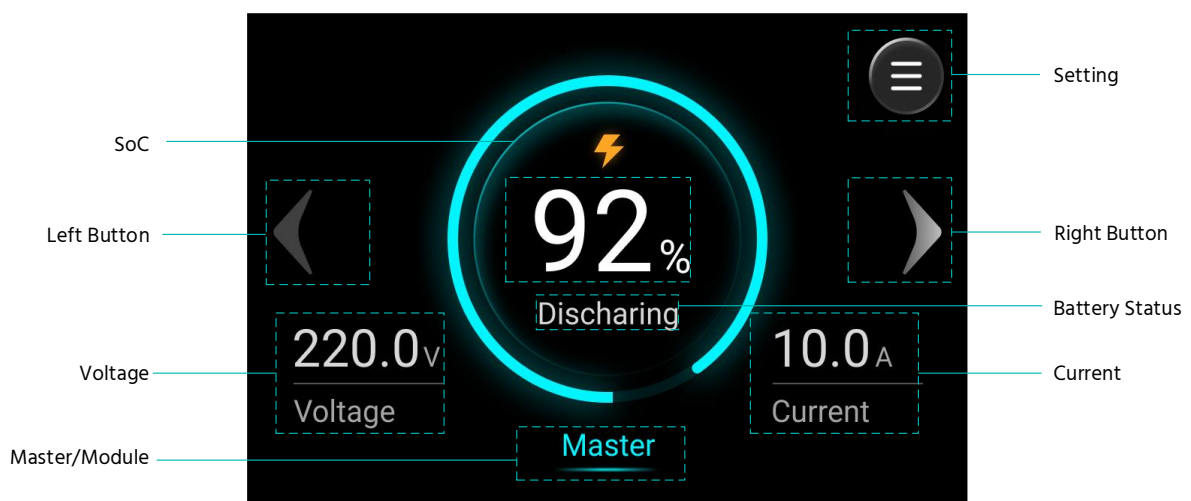

NOTE:

The image is for reference only. Please refer to the actual product.

From the main screen, tapping the SOC indicator in the center navigates to view detailed battery information.

When multiple batteries are connected in parallel, a dedicated "Master" interface will appear on the main screen. This interface shows summarized information for the entire battery cluster. Use the left and right buttons on the main display interface to switch between the "Master" and "Module" views.

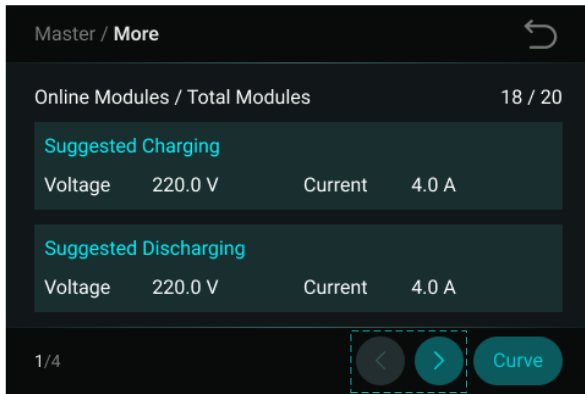

Screen 1

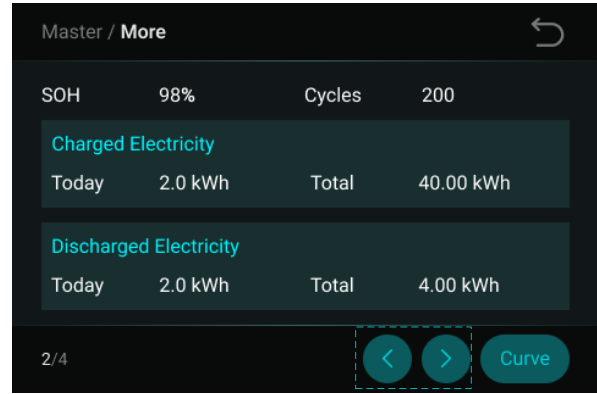

Screen 2

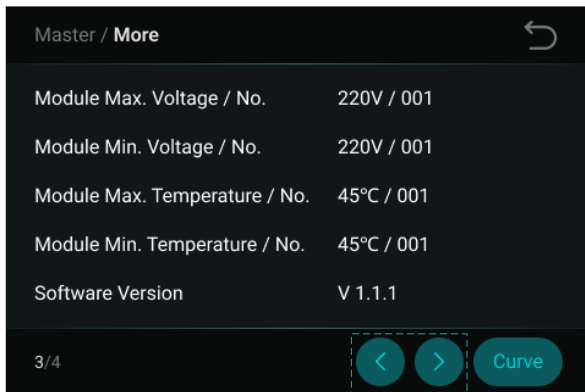

Screen 3

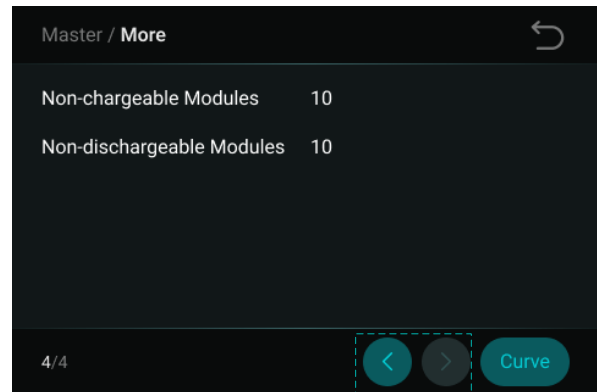

Screen 4

These screens can be navigated using the left and right arrow keys in the lower-right corner.

- Screen 1 displays the battery's suggested charging and discharging parameters, including voltage and current.
- Screen 2 displays the battery's State of Health (SOH), cycles, and total charged/discharged electricity.
- Screen 3 shows the battery voltage, temperature, and software version information.
- Screen 4 (Only master) shows the number of non-chargeable/non-dischargeable modules.

Tapping the "Curve" key in the lower-right corner of the main screen provides access to the curve of current, voltage and SoC.

7.2 Setting

Click  to enter the setting page as below.

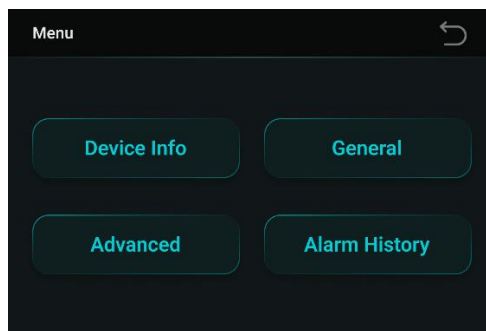

7.2.1 Device Info

Click *Device Info* to go to the Device Info page.

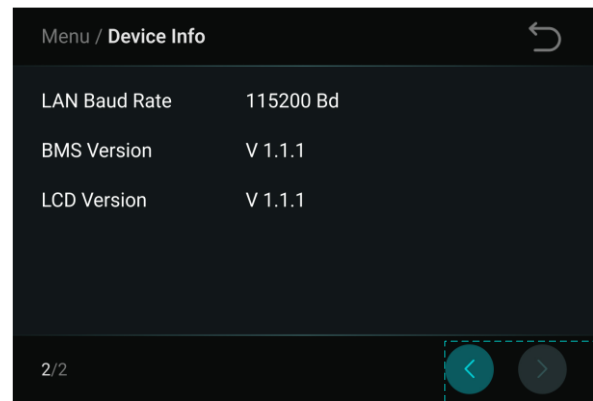

7.2.2 General Setting

Click *General* to go to the General page.

The General page allows for the configuration of the system time, date, screen timeout, and screen lightness.

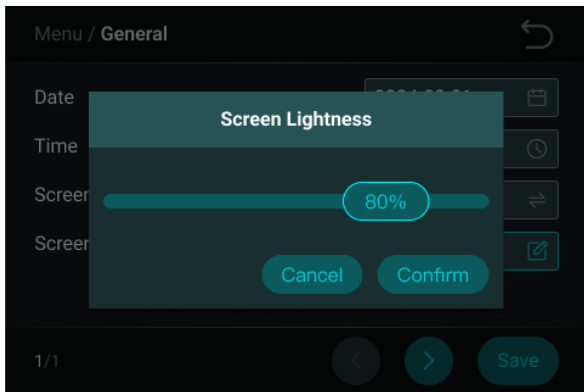
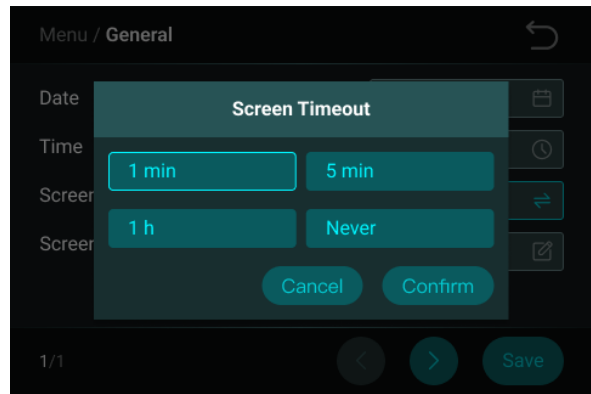
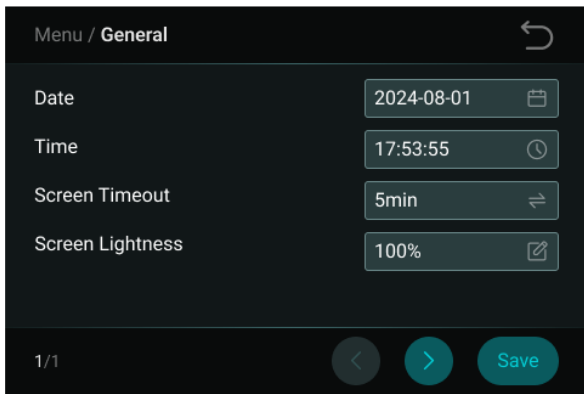

7.2.3 Advanced Setting

1. Click *Advanced* to go to advanced settings page, which require password authentication for entry.
2. Enter password.

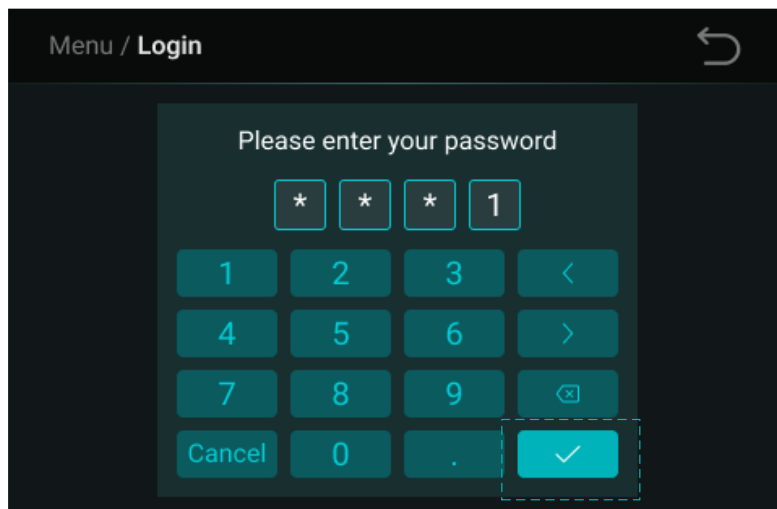

NOTE

The default password is 0001.

3. Go to Advanced Setting page.

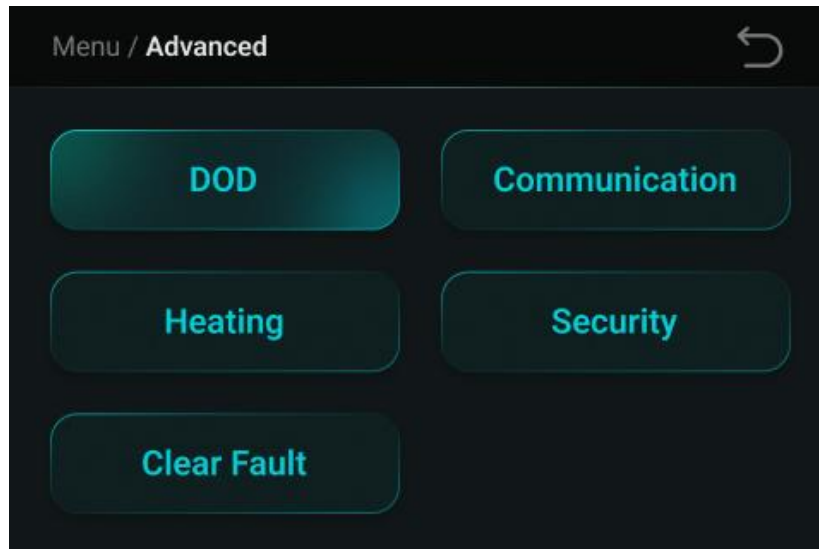

Click *DOD* to go to the DoD page, which allows users to customize the battery's depth of discharge. The default settings are a charge termination limit of 100% SOC and a discharge termination limit of 5% SOC. The system will automatically halt charging or discharging when the battery's SOC reaches either of the set values.

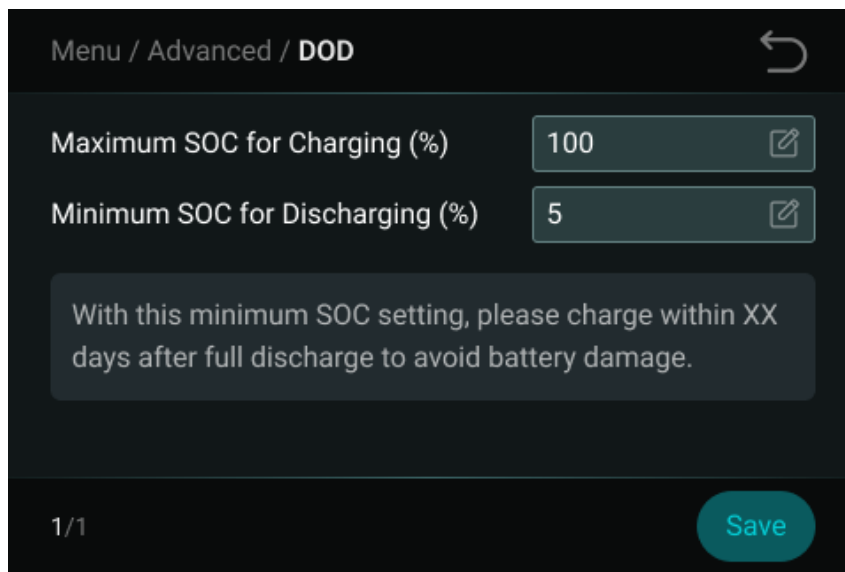

Click *Heating* to go to the Heating page. The Heating function is only available for the FB-L-16-Pro model (with low-temperature heating capability). This function is inactive for the standard FB-L-16 model and should not be configured. Once enabled, users can set the heating activation/deactivation temperature thresholds and the duration.

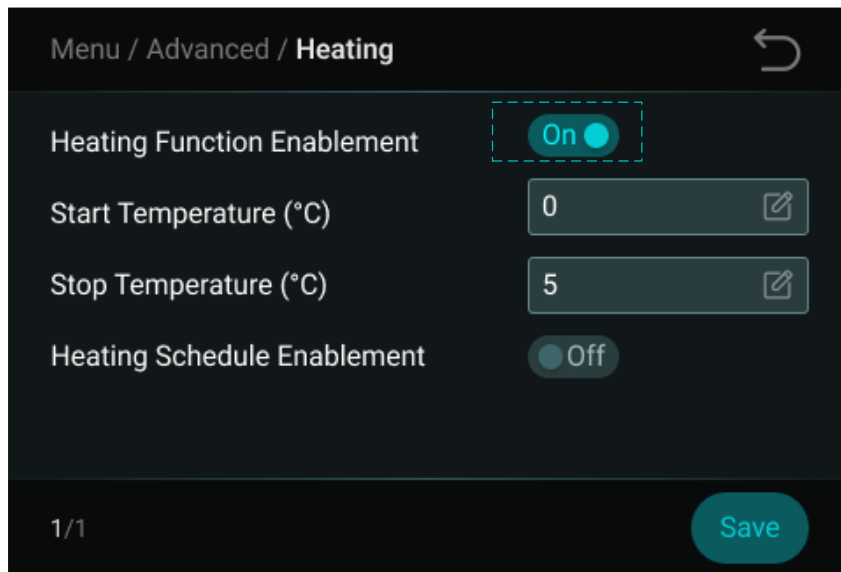

Click *Security* to go to the Security page. Users can reset the login password and enable the battery lock feature on the Security page. Once enabled, if the system shuts down abnormally, the battery will remain locked and inoperable after restarting. It must be unlocked via password authentication to resume operation. This feature can be configured based on user requirements.

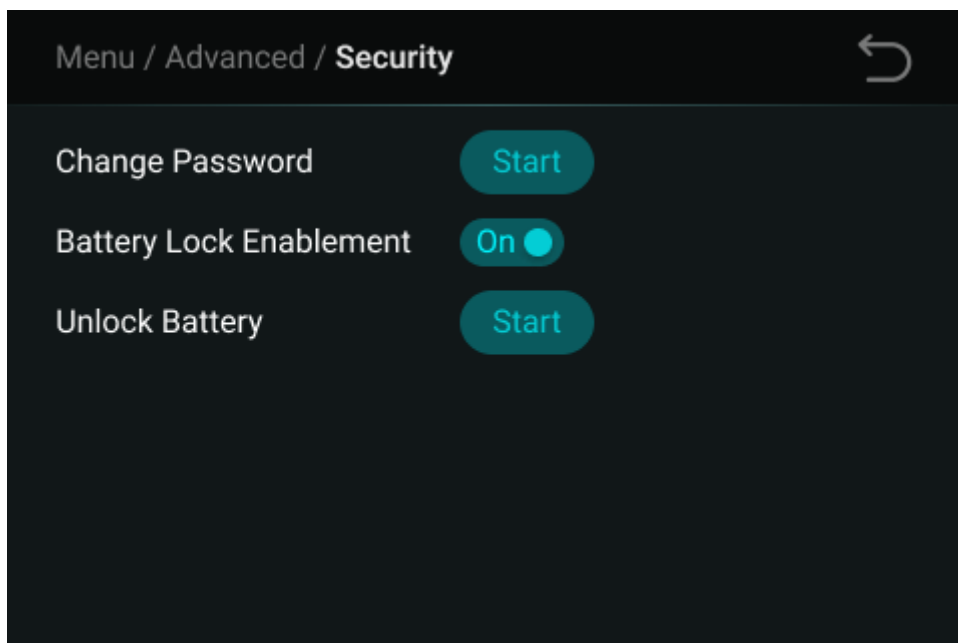

Click *Clear Fault* to go to the Clear Fault page. The Clear Fault function addresses critical faults that cause the battery to lock. This button should only be operated after a qualified technician has confirmed that the underlying fault has been fully resolved. If such a fault occurs, contact your distributor or service personnel for verification before any attempt to clear the fault.

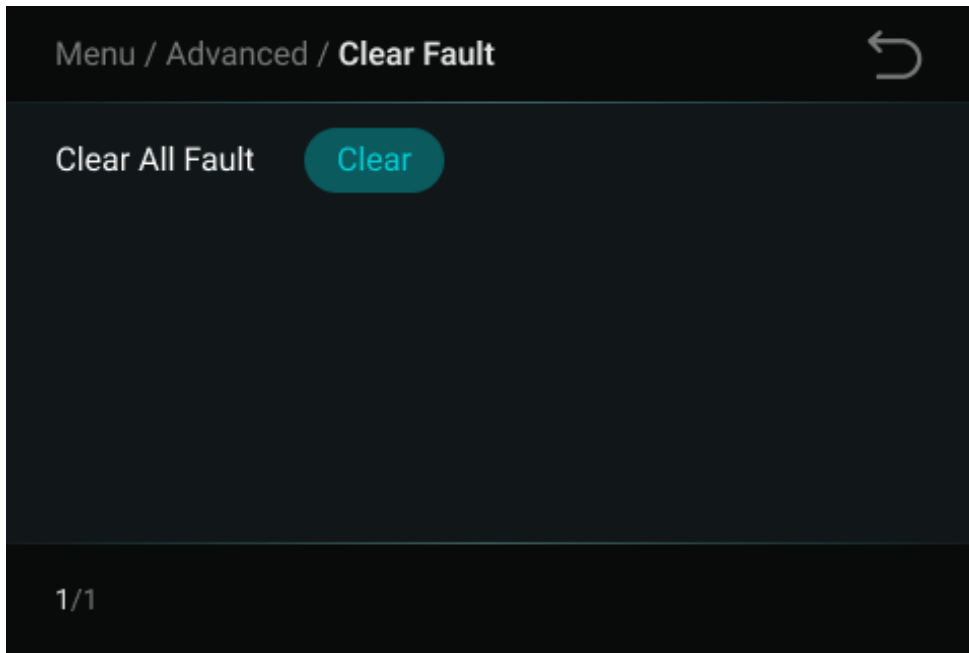

7.3 Alarm

When the device malfunctions, an alarm code will be displayed on the screen. Please follow the alarm code to troubleshoot the device.

Click the icon  to view the current alarm information of the battery.

8 Troubleshooting

Item	Condition	Reason	Troubleshooting Methods
Communication Related Problems	Unable to communicate with inverter on compatible list.	Pin definitions	Check whether the CAN or 485 communication connection and PIN definition of the battery are correctly connected to the corresponding PIN definition of the inverter.
			Please verify that the RS-485 communication baud rate set by the master battery is correct. The baud rate can be configured directly on the built-in display.
		Inverter Battery Setting Issue	Check whether the battery model selection is required in the inverter settings; the battery type must be selected as lithium battery or Pylontech battery.
Function Related Problems	Close the Power On switch, press and hold the Start button; the battery fails to start, however.	Capacity too low, or module over discharged.	Depending on the different battery terminal voltages, take the following 2 methods: If the battery terminal voltage is ≤ 45 VDC, use ≤ 0.05 C to slowly charge the module to avoid affecting SOH; If battery terminal voltage is > 45 VDC, use ≤ 0.5 C to charge. If the battery cannot start, turn off and repair the battery.
		BMS Damage	Use a multimeter to measure the battery module voltage. If the voltage is > 45 V but the battery fails to power on, the BMS may be damaged. Please contact your local distributor for repair.

		Battery Damage	If the module voltage is < 35V, the battery is severely undercharged and poses a safety risk. It must be scrapped as soon as possible.
	System fault persists after power-on.	System fault	Check the fault code and detailed description reported by the battery via the built-in display or the mobile app. Please contact your distributor for confirmation and repair.
Display Panel Faults	Display panel is blank	The battery is powered off, or the display has timed out and turned off.	After powering on the battery, touch the screen to activate it.
		Abnormal power supply to the display or a faulty display	If the screen remains blank after ensuring the battery is powered on, please contact your distributor for inspection, repair, or replacement.
	Display panel is unresponsive	Display panel damage	Please contact your distributor for repair or replacement. The mobile application can be used as a temporary alternative for viewing battery data and operation.
Heating Related Problems	The inability of batteries to heat up at low temperatures	Confirm whether the battery is a heating model.	Only FB-L-16-Pro supports heating. Please ensure the battery model is correct.
		Verify if the battery heating function is enabled.	The heating function can be turned on or off via the battery's function buttons. It is enabled by default at the factory. Please check if it was accidentally turned off during use.

		Battery temperature not reaching the heating threshold	Either the cell temperature is too low, exceeding the operable range; or the battery temperature is too high, not reaching the set heating activation temperature.
		Not within the heating time period	The heating time period can be set via the APP. If a heating time period is set, the battery will only heat within the specified time.
		Insufficient energy	The battery cannot activate self-heating due to low power. The PCS has no extra energy to charge and heat the battery.
	Heating function fault	Damage to heating film-related components	When a heating function fault is reported, this fault cannot be repaired. However, it can be temporarily masked via the function button. After masking, the battery can be used normally as a non-heating model. If you wish to retain the heating function, please contact your local distributor.
	The heating temperature fails to rise.	Insufficient heating current	When the PCS is charging and heating the battery, if the output power of the PCS is too low, it will fail to meet the heating power requirements.
		Heating film detachment	If the heating film has detached from the battery and the issue is confirmed not caused by insufficient heating current, please contact after-sales service personnel for replacement and repair.

When a data acquisition stick is optionally equipped and the acquisition stick is connected to the network, the battery will report specific faults to the APP. The faults reported by the battery can be viewed intuitively on the APP. Contacting after-sales service personnel based on the specific fault causes will result in higher efficiency.

Excluding the points above, if the faulty still cannot be located, turn off battery and contact your local distributor.

9 Emergency Situations

⚠ CAUTION

Caution: Damaged batteries may leak electrolyte or produce flammable gas.

Problem	Description	Action	
Leaking Batteries	If the battery pack leaks electrolyte, avoid contacting with the leaking liquid or gas. If anyone is exposed to the leaked substance, immediately perform the actions.	Inhalation.	Evacuate the contaminated area and seek medical attention.
		Contact with eyes.	Rinse eyes with flowing water for 15 minutes and seek medical attention as soon as possible.
		Contact with skin.	Wash the affected area thoroughly with soap and water, and seek medical attention as soon as possible.
		Ingestion.	Induce vomiting and seek medical attention.
Fire	The battery cell is catching fire.	<ol style="list-style-type: none"> 1. Firstly, cut off the external power supply. 2. Then use vast of water for suppression. 3. After extinguishing the fire, soak the battery in water and contact Pylontech or an authorized dealer. 	
	The cabling or other component (not battery cell) is catching fire.	<ol style="list-style-type: none"> 1. Firstly, cut off the external power source. 2. Then use dry powder fire or carbon dioxide extinguisher for suppression. 	
Wet Batteries	The battery module is wet or submerged in water.	<ol style="list-style-type: none"> 1. Cut off all power switch on inverter side. 2. DO NOT let people access it, and contact Pylontech or an authorized dealer for technical support. 	
Damaged Batteries	Damaged batteries are dangerous and must be handled with the utmost care. They are not fit for use and may pose a danger to people or property.	If the battery pack seems to be damaged, pack it in its original container, and then return it to Pylontech or an authorized dealer.	

10 Remarks

10.1 Recycle and Disposal.

If a battery (normal condition or damaged) needs disposal or needs recycling, follow the local recycling regulation (i.e. Regulation (EC) N° 1013/2006 among European Union) to process, and use the best available techniques to achieve a relevant recycling efficiency.



10.2 Storage, Maintenance and Expansion

1. If the battery needs to be stored for a long period, please refer to the following storage conditions and requirements:

Storage Temperature Range	Maximum Storage Duration	Battery Power Before Storage
-20~45°C	1 month	>30%
0-35°C	6 months	>50%

The maximum storage duration of the battery is 6 months. If this period is exceeded, the battery must be activated through charge-discharge cycles. It is recommended to perform 2~3 charge-discharge cycles on the battery before storing it again.

When different discharge lower limits are set, the maximum allowable storage time after a full discharge will be displayed on the screen. Please ensure that the battery is recharged within this indicated time to avoid damage caused by prolonged storage.

2. It is suggested to check the connection of power connector, grounding point, power cables and screws every year after installation. Make sure that there is no loose, no broken, no corrosion at connection points. Check the installation environment such as dust, water, insect etc. Make sure that it is suitable for IP65 battery system.
3. A new battery module can be added onto an existing system at any time. Make sure that the new battery is acting as the master. The new module, due to a higher SOH may have a difference on SOC with existing system, but it will not affect the parallel connection system performance.



Pylon Technologies Co., Ltd.

No.300, Miaoqiao Road, Kangqiao Town

Pudong New Area, Shanghai 201315, China

T +86-21-51317699

E service@pylontech.com.cn

W www.pylontech.com.cn