

LP SERIES-GENERAL PURPOSE

LP12-200 (12V200Ah)

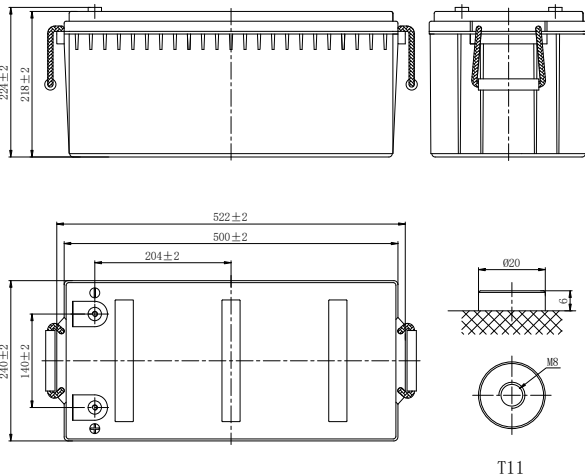

CHARACTERISTICS

Item	Specifications	
Rated Voltage	12V	
Nominal Capacity (25°C)	C ₁₀ : 1.80V/cell	200Ah
Dimension	Length	522mm (20.6inches)
	Width	240mm (9.45inches)
	Container Height	218mm (8.58inches)
	Total Height	224mm (8.82inches)
Approx Weight	59.0kg (130.1lbs)	
Terminal	T11(M8)	
Container Material	ABS (UL94 HB or V-0 optional)	
Short-circuit current	3600A	
Internal Resistance (25°C)	Approx 3.2 mΩ (Fully charged)	
Operating Temp. Range	Discharge	-15~50°C (5~122°F)
	Charge	-20~40°C (-4~104°F)
	Storage	-15~40°C (5~104°F)
Nominal Operating Temp. Range	25±3°C (77±5°F)	
Max. Charging Current (25°C)	0.3C	
Charge voltage (25°C)	Standby Use	Cycle Use
	2.25-2.30V/cell	2.35-2.40V/cell
Temp. Coefficient	-3mV/cell/°C	-5mV/cell/°C
	40°C (104°F)	103%
Effect of temp. to Capacity	25°C (77°F)	100%
	0°C (32°F)	86%
	≤3% per month at 25°C (77°F). LP series batteries may be stored up to 6 months at 25°C (77°F) and then a freshening charge is required. For higher temperatures the time interval will be shorter.	
Self Discharge		

DISCHARGE TABLE

Constant Current Discharge (Amperes) at 25°C (77°F)																
F.V/Time	5min	10min	15min	20min	30min	45min	1h	1.5h	2h	3h	4h	5h	6h	8h	10h	20h
1.85V/cell	328.7	287.1	254.0	199.7	178.6	130.6	110.6	80.2	67.4	49.4	38.8	33.7	29.7	22.8	18.9	10.0
1.80V/cell	372.4	325.8	287.8	225.8	194.4	138.4	114.6	82.9	69.6	53.7	41.4	35.4	31.9	24.0	20.0	10.4
1.75V/cell	403.2	353.4	311.6	243.8	198.4	143.4	120.2	87.1	73.3	54.7	42.2	36.0	32.1	24.1	20.1	10.5
1.70V/cell	428.2	376.8	330.9	258.5	202.4	146.2	122.6	88.9	74.7	55.8	42.9	36.6	32.3	24.5	20.2	10.6
1.67V/cell	440.8	388.7	340.6	265.5	205.3	148.4	124.4	90.2	75.8	56.3	43.6	37.4	32.4	24.8	20.5	10.7
1.60V/cell	454.4	402.0	351.1	272.4	208.3	150.5	126.2	91.5	76.9	56.8	44.1	37.9	32.7	25.2	20.7	10.9
Constant Power Discharge (Watts/cell) at 25°C (77°F)																
F.V/Time	5min	10min	15min	20min	30min	45min	1h	1.5h	2h	3h	4h	5h	6h	8h	10h	20h
1.85V/cell	721.2	529.0	480.9	379.9	341.2	251.1	213.9	155.5	131.1	96.6	76.1	66.3	58.6	45.3	37.6	20.0
1.80V/cell	806.9	591.8	537.9	424.9	368.6	264.3	220.4	160.0	134.7	104.4	80.9	69.4	62.7	47.5	39.3	20.7
1.75V/cell	861.1	631.6	574.1	453.5	373.2	272.2	230.2	167.4	141.3	106.1	82.2	70.4	63.0	47.6	39.7	20.8
1.70V/cell	905.3	664.0	603.5	476.8	377.5	275.7	233.6	170.0	143.5	107.8	83.3	71.4	63.3	48.3	40.0	21.0
1.67V/cell	920.0	674.8	613.3	484.5	380.2	278.2	235.7	171.6	145.0	108.3	84.3	72.6	63.4	48.9	40.5	21.3
1.60V/cell	932.9	684.2	621.9	491.3	381.8	279.6	237.5	173.0	146.2	108.8	84.9	73.3	63.6	49.4	40.9	21.5

LP SERIES-GENERAL PURPOSE

LP12-200 (12V200Ah)



APPLICATIONS

- All purpose
- Uninterruptable Power Supply (UPS)
- Electric Power System (EPS)
- Emergency backup power supply
- Alarm and security system
- Communication power supply
- DC power supply
- Auto control system

GENERAL FEATURES

- 10 years design life (25°C)
- Lead calcium alloy, sealed design, no watering required
- Puncture resistant micro-porous glass mat separators extend life
- Unique technology optimizes power capacity, cell consistency, and long-term reliability
- Designed for a wide range of applications

STANDARDS

- Compliance with IEC 60896 standards, EU Battery Directive
- UL, CE Approved
- Manufactured in Leoch@IATF 16949, ISO 45001, ISO 9001 and ISO 14001 certified production facilities

Discharge Characteristics

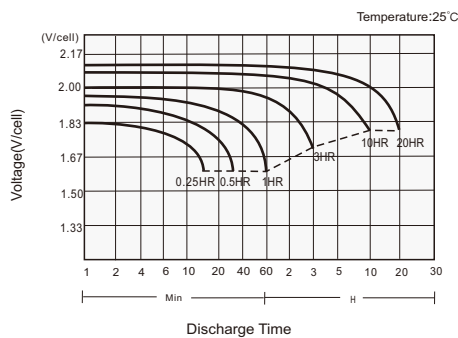

Charging Characteristics

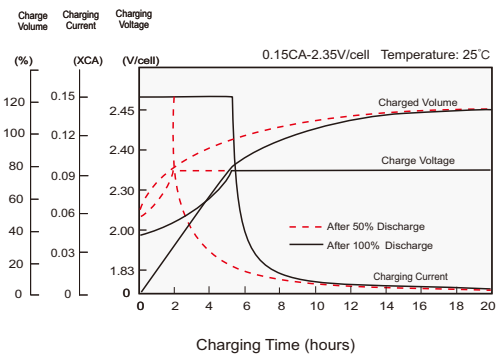

Effects of Temperature on Capacity

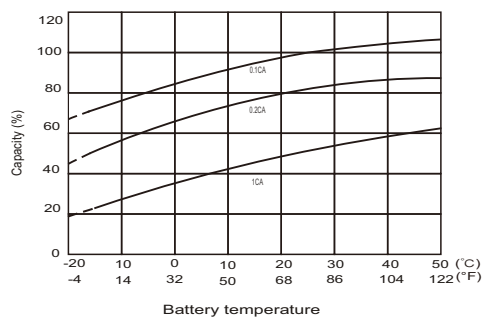

Self Discharge Characteristics

