

# Ultracell®

'Quality in Every Language'

LIT200-12

12V 200Ah/2560Wh

Lithium Series

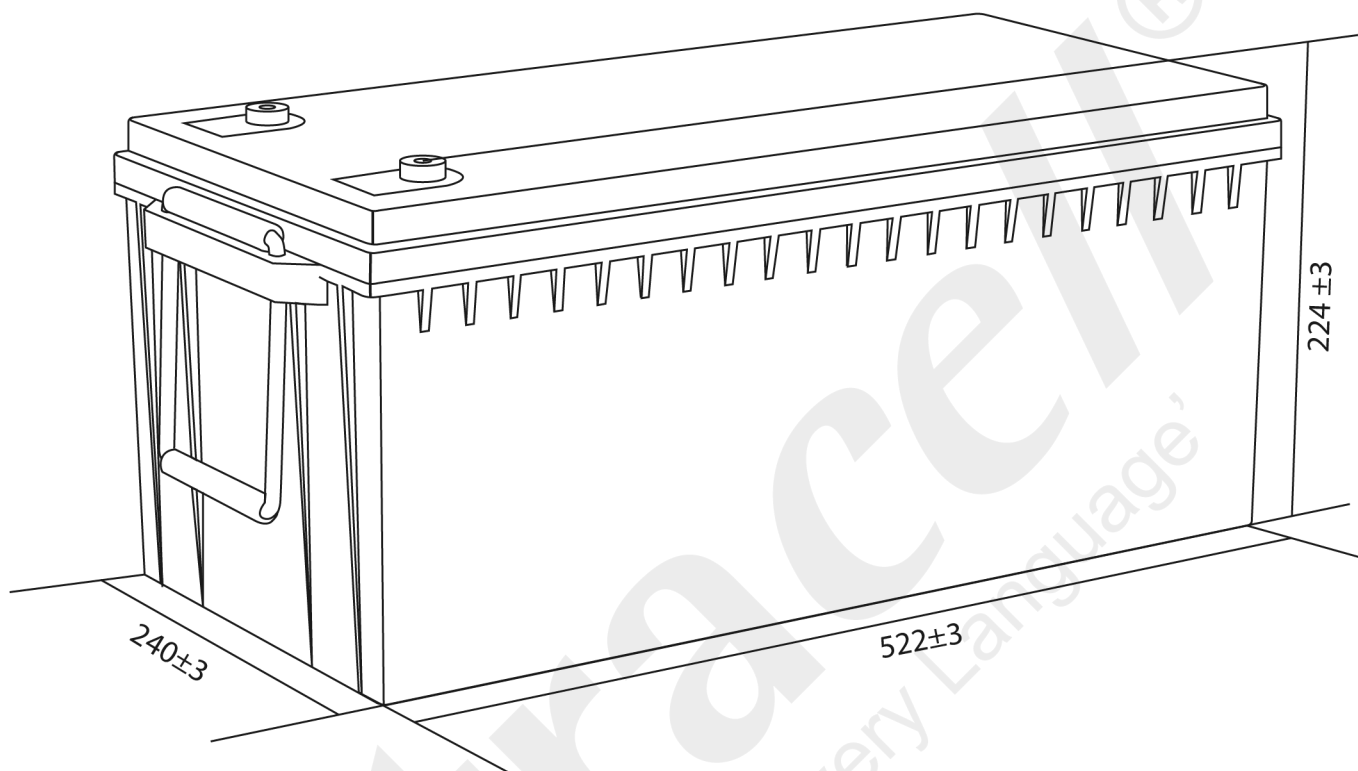

## Technical Dimensions (mm)

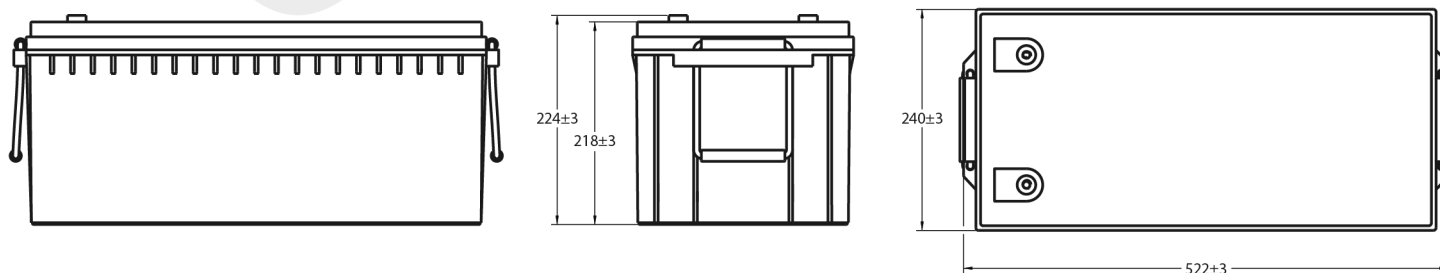



Image



Terminal Dimensions (mm)

Standard Terminal: F11

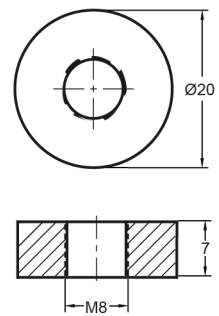

Technical Specification

<b>Output</b>	Nominal Voltage	12.8V
	Nominal Capacity	200Ah
	Energy	2560Wh
<b>Terminal Type</b>	Standard Terminal	F11
<b>Container Material</b>	Standard Option	ABS
	Flame Retardant Option (FR)	ABS (UL94:VO)
	IP Class	IP65
<b>Standard Charge</b>	Charge Voltage	14.6±0.2V
	Charge Mode	0.2C (CC) charge to 14.6V, then charge (0.02C) (CV)
	Charge Current	60A
	Max. Charge Current	120A
	Standard Charge Current	14.6V ± 0.2V
<b>Standard Discharge</b>	Rated Discharge Current	60A
	Max. Discharge Current	120A
	Discharge Cut-off Voltage	10V
<b>Internal Resistance</b>	≤20mΩ	
<b>Discharge Characteristics</b>	Operating Temp Range	Charge: 0 ~ 55°C
		Discharge: -20 ~ 60°C
		Storage: -20 ~ 45°C
<b>Efficiency of Charge</b>	100% @0.5C	
<b>Efficiency of Discharge</b>	96~99% @0.5C	
<b>Cycle Life</b>	≥2000 cycles @ 1C 100%DOD	
<b>Battery Management System</b>	Complete with BMS unit measuring current, voltage, single cell surface temperature and the ambient temperature of the battery.	

Self Discharge

Ultracell® LIT batteries may be stored for up to 2 years at 25°C and then a refresh charge is required. For higher temperatures the time intervals will be shorter.

Transportation

Ultracell® LIT Batteries will be at 30% State of Charge when shipped in accordance to the applicable international and national government regulations. To prevent damage during transit, ensure packaging is safe and secure. Keep battery dry and away from direct sunlight. Suitable for all transportation vehicles.



Different Rate Discharge Curve (25°C)

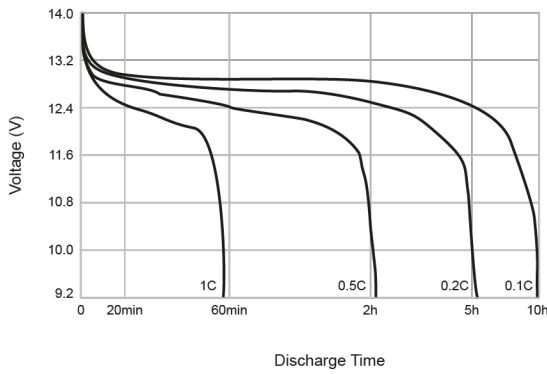

Different Temperature Discharge Curve (0.5C)

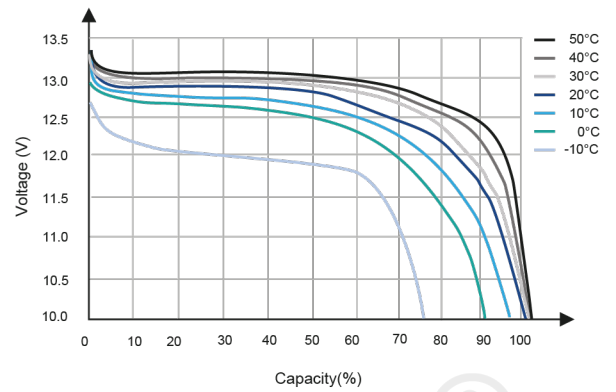

State of Charge Curve (0.5C, 25°C)

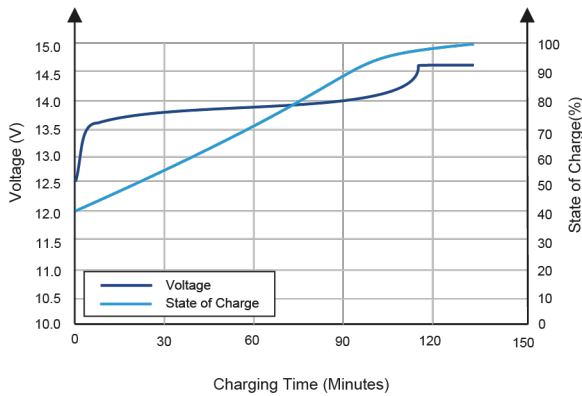

Charging Characteristics (0.5C, 25°C)

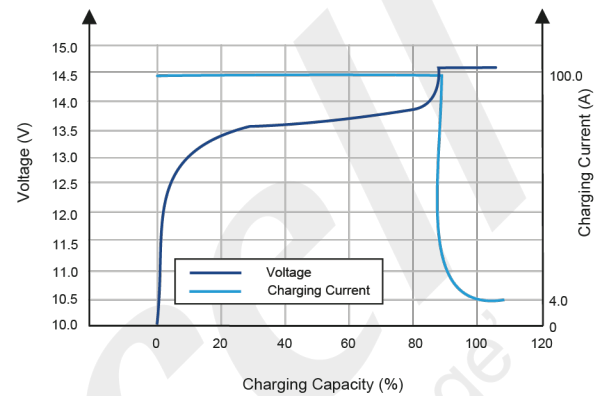

Cycle Life on D.O.D (25°C)

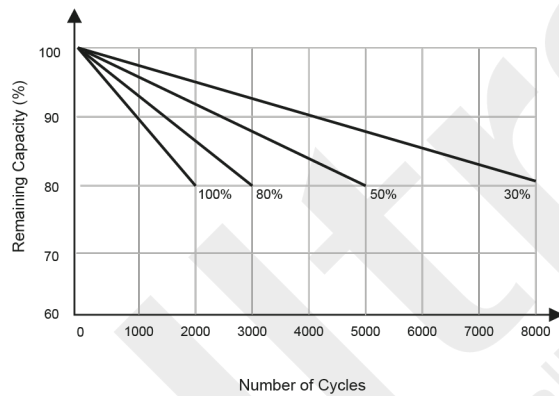

Temperature on Self Discharge Curve

